

# **RS900ER/RS901 SERIES I**

## **REMOTE ENGINE STARTING SYSTEM INSTALLATION INSTRUCTIONS**

This Remote Start Module provides the following features:

### **SELECTABLE ENGINE SPEED SENSING:**

- Tach, Semi-Tachless, & Vacuum

### **TACH AMPLIFIER:**

- For dirty or low-level tach signals

### **PROGRAMMABLE RUN TIME:**

- 10, 20, or 40 minutes

### **4 ON-BOARD RELAYS:**

- Main Ignition (IGN1)
- IGN2 / Accessory
- Starter
- Parking Light

### **REMOTE KEYLESS ENTRY:**

- Controls power door locks

### **SECURITY STARTER DISABLE**

### **TIMED SELF-START MODE:**

- Program vehicle to start every  
1-4 Hours

### **CODE / TACH LEARNING CIRCUITRY**

### **TWO PROGRAMMABLE MULTI-FUNCTION OUTPUTS FOR:**

- OEM Alarm Disarm
- Throttle Pulse for Carbureted vehicles
- Starter Disable / Anti-Grind Output
- Remote output for trunk pop
- Host alarm sensor disable
- Defroster Activation

### **HOOD / BRAKE SAFETY CIRCUITRY**

### **VALET MODE / OVERRIDE**

### **OEM ALARM / KEYLESS ACTIVATION:**

- Lets a Factory Keyless Entry or Alarm  
AUX output activate the Remote Start

### **DIESEL START COMPATIBILITY**

### **DELAYED REMOTE CONTROL OPERATION:**

- Prevents accidental Remote Starts

Some of the features listed above are optional connections, and may require additional parts and labor.

### **TECHNICAL SUPPORT: 1-800-998-6880**

Monday - Friday 8:00am - 4:30pm Pacific Time

Web Site: [www.crimestopper.com](http://www.crimestopper.com)

E-mail: [tech-support@crimestopper.com](mailto:tech-support@crimestopper.com)

CRIMESTOPPER SECURITY PRODUCTS, INC.

1770 S. TAPO STREET, SIMI VALLEY, CA. 93063

This device complies with FCC Rules part 15. Operation is subject to the following two conditions:  
(1) This device may not cause harmful interference, and (2) This device must accept any interference that may be received, including interference that may cause undesired operation. The manufacturer is not responsible for any radio or TV interference caused by unauthorized modifications to this equipment. Such modification could void the user's authority to use the equipment.

# INSTALLATION CONSIDERATIONS / WARNINGS

To ease and reduce installation time, we suggest you consider the following points before starting.

1. Determine most suitable locations for all components to be placed. These components include: the module itself, override / programming switches, and possible relays.
2. Use a Volt-Ohm meter to test and locate all connections.
3. Record all color codes of vehicle wiring to be used for reference. This will save time by not having to re-test the same wires over again.
4. Allow enough wire to create a service loop with strain relief, should servicing be required. This will also allow easier access and mounting.

**\*\*FOR SAFETY REASONS, DO NOT INSTALL RS900/901 in vehicles with MANUAL TRANSMISSIONS.\*\*** If accidentally left in gear, a remote started vehicle could become a self-propelled threat to life and property.

**DO NOT** extend the RS-900 Remote start ignition harness length. Mount the module so that main harness reaches all ignition switch wiring. Extending these wires could result in poor performance.

**DO NOT** route any wiring that may become entangled with brake, and gas pedals, steering column, or any other moving parts in the vehicle.

**DO NOT** exceed the rated output current of any circuit on the Remote start module. Failure to observe this warning will result in damage to the unit.

**DO NOT** remote start the vehicle in a closed garage. Make sure that the garage door is open or there is adequate ventilation. Failure to observe this rule could result in injury or death from poisonous Carbon Monoxide fumes.

**Warning:** This system DOES NOT HAVE engine over-rev protection. Make certain vehicle throttle linkage operates properly and does not stick. A stuck throttle will cause severe engine damage

# WIRING INSTRUCTIONS

## **PROGRAM/OVERRIDE SWITCH: 2 PIN PLUG**

This switch is used primarily for programming features of the RS900/901. However, if the Anti-Grind/Starter disable feature is installed, you **MUST INSTALL** this switch. This switch will allow the user to override the starter disable in the event of a non-operating remote control.

## **8 PIN PLUG:**

### **PIN 1: TAN: MULTI-FUNCTION OUTPUT 1**

This output comes pre-programmed to provide a ground pulse to disarm the vehicles' **FACTORY** anti-theft system prior to ignition on and 2 seconds after start for Defroster activation. This output can also be changed to operate as a Remote controlled output for trunk release. **See Programming Section.**

**For OEM Disarm:** Connect this wire to the vehicles' anti-theft disarm wire. This wire is usually found coming off the Driver's door keyswitch or the Factory Anti-theft control module.

**For Defroster Activation:** Connect this wire to the vehicle's defroster activation switch. It may be necessary to use a relay. *If using both OEM Disarm and Defrost Activation, Use relays to isolate the two circuits from operating simultaneously, or use diodes to isolate interference.*

**PIN 2: ORANGE: MULTI-FUNCTION OUTPUT 2**

Output 2 comes pre-programmed to operate as the Anti-Grind/Starter Disable output. It can also be used for the sensor disable circuit for a host alarm. This output activates whenever a remote start is requested, and when the vehicle is remotely locked with the transmitter. Connect this wire to terminal 85 of a relay. See diagram below.

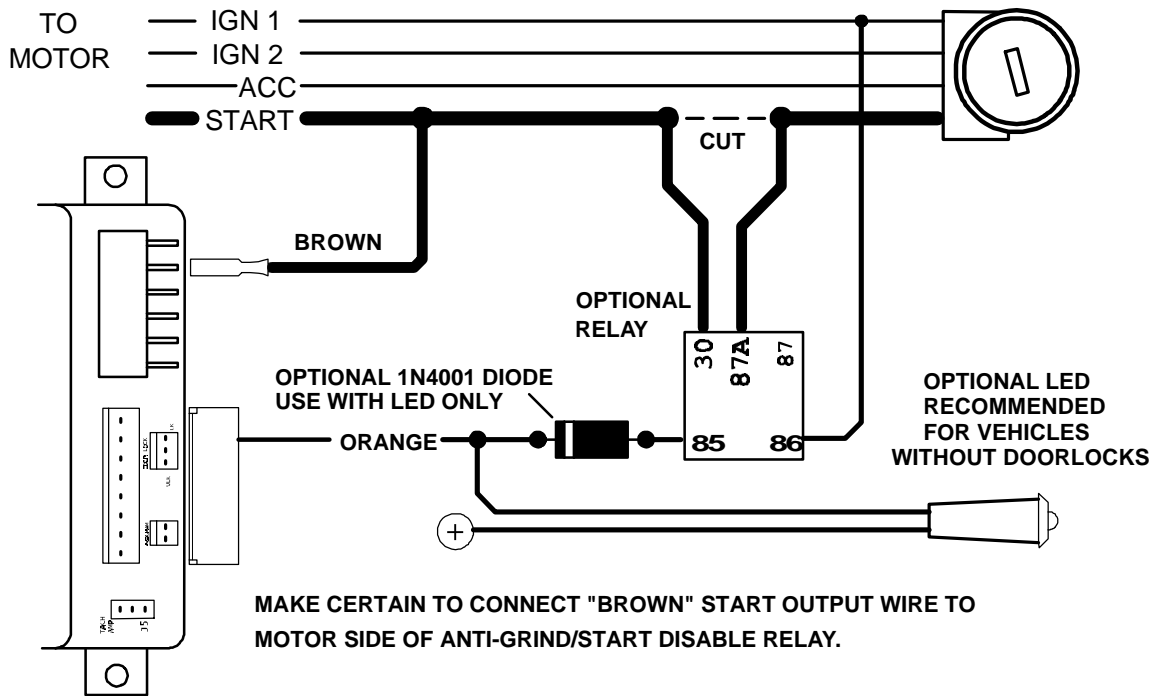

**PIN 3: BLACK: MAIN SYSTEM GROUND**

Connect to chassis metal of the vehicle. An existing bolt or screw MAY provide an adequate ground, or drill a small hole, scrape away paint and attach using a sheet metal screw & star washer. If this wire is not connected OR connected to a point on the vehicle that provides a poor ground, undesirable and inconsistent operation will occur. This is a mandatory connection.

**PIN 4: YELLOW: IGNITION 1**

NEGATIVE (-) OUTPUT FOR RELAY

Use this wire when the vehicle requires a second IGNITION1, IGNITION2, or ACCESSORY wire to be activated. This occurs commonly in Toyota, and late model GM cars. See diagram below:

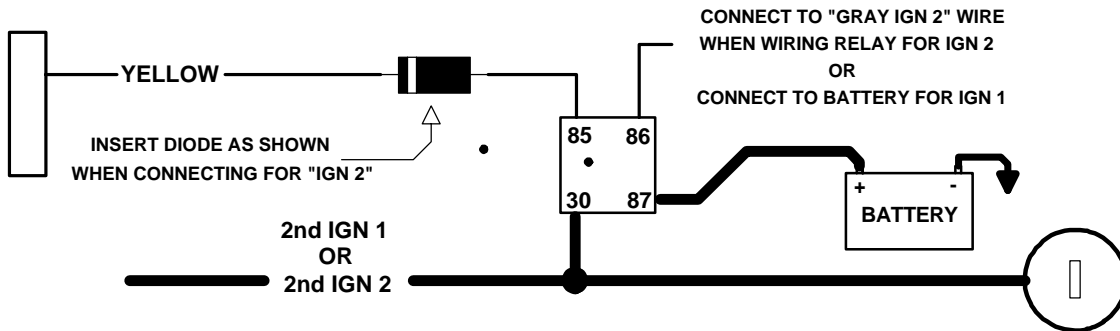

### PIN 5: GREEN: (-) START ACTIVATION TRIGGER

This wire allows a host alarm (-) Negative Auxiliary Channel Output to activate a Remote Start or it can be connected to a Negative wire of a factory keyless entry system. If the Factory Keyless Entry System wire can produce a Negative output for 1 second or 3 short pulses within 5 seconds, that system could also be used to trigger a remote start. See diagram below for Factory Keyless interface.

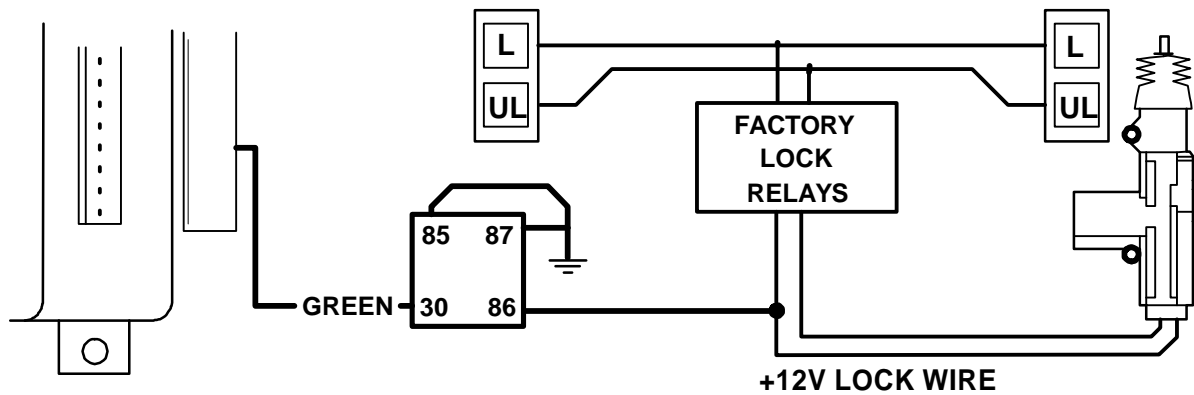

### PIN 6: GRAY: - HOOD SWITCH

Connect this wire to a switch that is at ground when the hood is open. If an existing switch is not available, then one must be installed. When this wire is grounded, the remote start is inhibited. This is a mandatory connection!

### PIN 7: PURPLE: + BRAKE RESET

Connect PURPLE wire to the side of brake pedal switch that shows +12 volts ONLY when pedal is depressed. This will turn off the remote start if someone attempts to drive the car without the keys or if the Ignition key is not turned on all the way. Brake pedal must be pressed for at least 1 second before reset will occur.

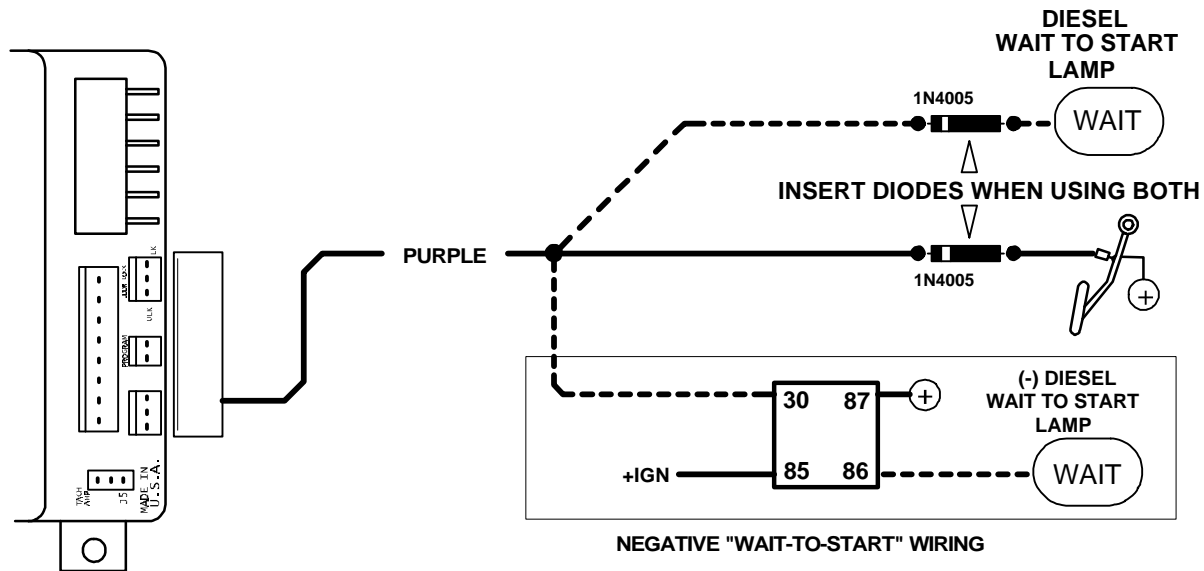

### PIN 8: RED/WHITE: (+/-) TACHOMETER/VACUUM SENSE

This wire MUST BE CONNECTED to the vehicle to sense the engine running. This is so the control module can control the starter motor to determine when to disengage the starter and to prevent the starter from engaging when the engine is running.

This system has three methods of sensing an engine running condition:

- **True Tach Learning:** This is the best and most reliable method.
- **Semi-Tachless/Timed Starting:** An alternative for vehicles with hard to locate tach sources.
- **Vacuum Sensing:** When all else fails.

## TACH LEARNING MODE

The TACH LEARNING MODE is the most reliable and consistent method of engine speed sensing. This wire looks for the pulsing signal that is created to monitor the engine speed or fire the coil. Most modern ignition systems utilize a crankshaft sensor to monitor the engine speed. There are 4 different types of signals that may provide adequate signal for TACH SENSE:

**Type 1** - Will be a computer-controlled ignition. On these systems the engine speed reference (tach) may come from several possible locations. The wire may be found at: Distributor, Ignition Module, Coil Pack, Engine Computer, or Crankshaft Sensor. *THIS WILL BE THE MOST RELIABLE AND CONSISTENT SIGNAL.*

**Type 2** - Will be a standard ignition coil. Connect the RED/WHITE 22-gauge wire to the negative(-) side of coil. *Note: The coil MAY NOT BE A GOOD LOCATION FOR TACH SOURCE. The coil wire may be too noisy for the system to detect a clean signal and/or the vehicle uses a Multi-spark ignition system that varies the spark.*

**Type 3** - Will be computer controlled fuel injection solenoids. This wire can be found at the Injectors in the engine compartment or at the engine computer.

**Type 4** - Will be the Alternator Stator pin on the alternator. This is found on many GM and Ford Diesel trucks from the mid 1980's through the mid 1990's.

**Use the Tach Finder Mode below to locate your tach source wire.**

## TACH-FINDER MODE

TACH-FINDER MODE is a unique feature to help installers easily identify wires which may be POSSIBLE sources for an engine speed reference by using the same RED/WHITE wire to probe ANY wiring, WITHOUT RISK TO THE COMPUTER SYSTEMS.

Tach-Finder may be operated by following the procedure below:

- 1) OPEN HOOD (ground GRAY hood switch wire) and Start engine.
- 2) Depress and Hold the BRAKE PEDAL and THEN PRESS THE PROGRAM BUTTON until the parking lights come on solid.
- 3) Connect the RED/WHITE tach wire to a scribe or sharp probe. *It may be necessary to extend RED/WHITE wire.* Probe the wires that may provide the proper signal. **Warning:** be certain to protect yourself from electrical shock!!
- 4) Start probing wires, When a wire with a pulsing signal is probed, the parking lights will start FLASHING.
- 5) At this time, turn engine/ignition off. Parking lights will stay ON.
- 6) Verify tach signal. Turn Ignition ON but DO NOT START ENGINE and probe the same wire.
  - A) If parking lights start FLASHING, you have found a DATA wire. This wire will tell the system the engine is running even if it the engine is not running. RESTART ENGINE and Repeat steps 4-6 with another wire.
  - B) If parking lights stay SOLID then START ENGINE. If park lights stay on SOLID after engine is started, there is no tach source. Repeat steps 4 through 6 to locate another wire. If park lights start FLASHING after engine is started, the tach source may be valid.
- 7) Turn engine OFF, park lights will remain ON. Permanently connect RED/WHITE wire to the located tach lead.
- 8) Now it is time to **PROGRAM the TACH REFERENCE:**
  - A) Start engine (with hood open), parking lights should start flashing.
  - B) Depress and hold BRAKE PEDAL down.
  - C) Press and hold PROGRAM SWITCH for 2 seconds. Parking lights will stop flashing while button is depressed.
  - D) Turn Ignition OFF, close hood. Parking Lights will still be ON. Tach Programming is now complete.
  - E) Depress BRAKE PEDAL to clear parking lights.

# TACH WIRE TROUBLESHOOTING

If all remote start wiring has been completed, attempt a remote start. If engine starts, and starter disengages quickly, and engine continues to run, the tach wire has been properly connected.

\*\* If system does not remote start properly, you will have to locate a different tach wire and reprogram.

AN INADEQUATE TACH SOURCE WILL PRESENT ANY VARIETY OF THE FOLLOWING PROBLEMS:

- Starter stays engaged after engine starts.
- Starter releases properly when engine starts, but engine then stalls BEFORE the time out. System may re-start.
- Starter releases properly, and engine runs, but then starter re-engages. (This makes a terrible grinding noise and the system must be shut off as quickly as possible to prevent damage to starter and flywheel). See "Tach Amplifier" below and on next page for other alternatives in solving starting problems!

## TACH AMPLIFIER

The Tach Amplifier feature is capable of detecting engine speed inductively (not connected directly but rather placed next to) from a spark plug wire or other source. This Tach Amp also has the ability of picking up very low voltage signals (as low as 1 volt) from vehicle computer modules, which more and more are driving the Tachometers in newer vehicles. In addition to the ability to detect signals inductively, the tach amplifier also conditions and smoothes the signal to prevent spiking and glitches from influencing the Remote Start processor. Tach amp is turned on or off by a jumper plug on the unit next to the harness connectors. The unit is shipped with the tach amp off. Tach amp should be used only in cases where an acceptable factory tach wire cannot be easily located. SEE DIAGRAM.

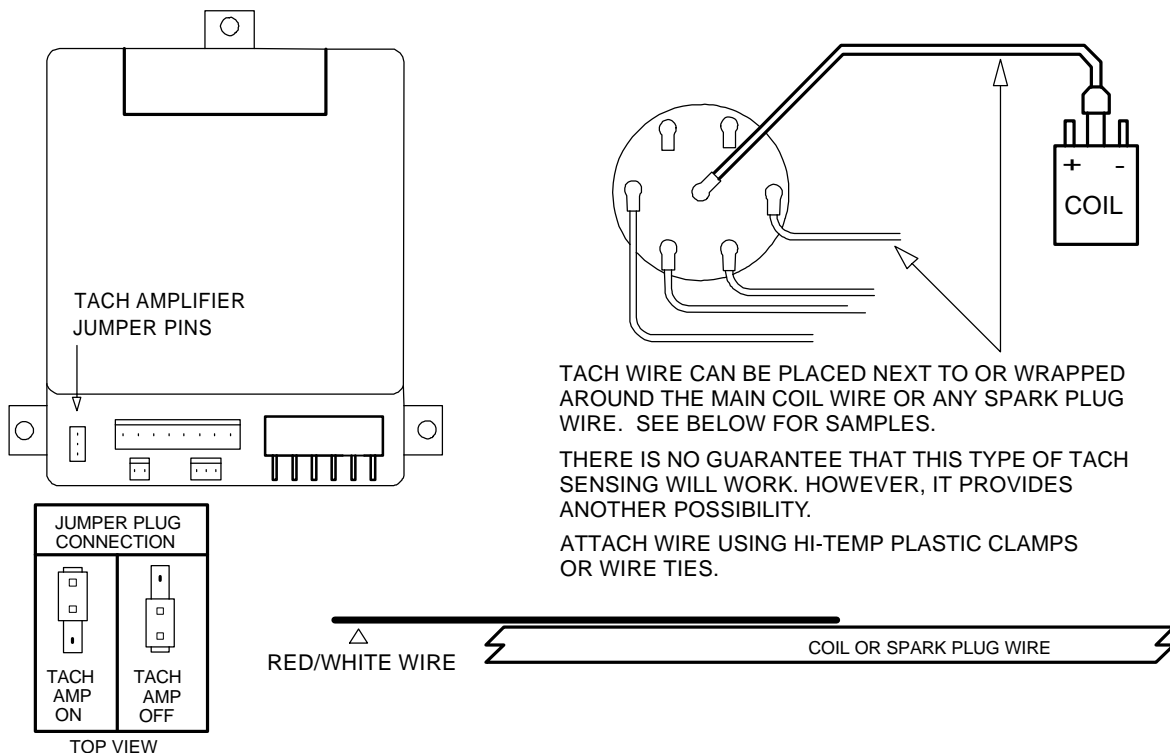

## SEMI-TACHLESS MODE

This new feature provides an easy method of starting the vehicle without locating the exact tach wire required. It uses a timed crank output combined with the tach wire as a crude pulse monitor. This combination prevents the starter from engaging into an already running engine and provides a reliable method of detecting when restart is required. There are 4 different crank times available for use.

### HOW TO USE THIS FEATURE:

- 1) Program the "Engine Sense" for "Timed Crank".
- 2) Next program the "Crank Time" to the appropriate time required for engine starting. This is determined by starting the engine with the key and estimating the amount of time it takes before the engine begins to run. We recommend starting with the minimum time which is already preset for 0.75 sec.
- 3) Connect the RED/WHITE tach wire to ANY negative coil trigger wire, OR see Tach Amplifier instructions on previous page. The system is now configured for Semi-Tachless operation.

**WARNING:** This method of starting the vehicle is not as reliable as using the TRUE TACH LEARNING. This method should be used only in the event that a tach wire can not be located using the normal tach programming and tach amplifier. When using this method, there may be certain operating anomalies requiring seasonal adjustments. These are, but not limited to:

- Starter may undercrank in extreme cold weather. Vehicle may start on 2nd or 3rd attempt, or will require programming.
- In warm weather starter may tend to overcrank, and may require reprogramming from the winter setting.

## VACUUM SWITCH

*This is to be used only in the event that a tach sense wire can not be found.* A simple Vacuum controlled switch, installed on the intake side of the engine, is used to signal the starter module that the engine is running. When the engine is NOT running, the switch rests at ground. When the engine starts, the engine vacuum opens the switch causing the ground to go away. This tells the starter module the engine is running. Connect Vacuum Switch per the instructions included with switch. Vacuum mode is programmable. Make certain tach amplifier is off.

## 3 PIN GREEN ACCESSORY PLUG

**PIN 1: EMPTY, PIN 3: EMPTY**

**PIN 2: ORANGE: OEM RE-ARM WIRE**

This wire provides a negative output in sequence with the lock pulse of the system. This wire is designed to be connected to the door pin switch wire to simulate a door being open when the system is locking in order to ARM some types of OEM Factory Security Systems. This wire can be connected directly to an Negative OEM arming wire if one is available.

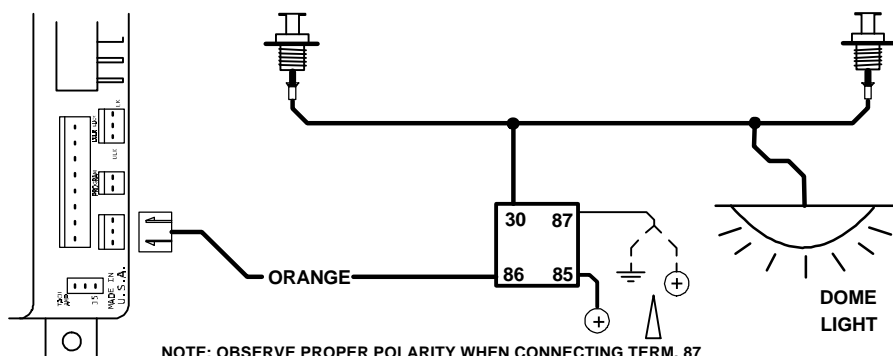

# IGNITION SWITCH WIRING

## 6 PIN HIGH-CURRENT SPADE CONNECTORS:

**PIN 1: RED 14Ga.: BATTERY CONSTANT FUSED 30A**

**PIN 2: BROWN 14Ga.: STARTER OUTPUT - 30A**

**PIN 3: GRAY 14Ga.: IGNITION 2 - 30A**

**PIN 4: WHITE 18Ga.: + PARKING LIGHTS 10A SEE NEXT PAGE**

**PIN 5: PINK 14Ga.: IGNITION 1 - 30A**

**PIN 6: RED 14Ga.: BATTERY CONSTANT FUSED - 30A**

See diagram below for connection information:

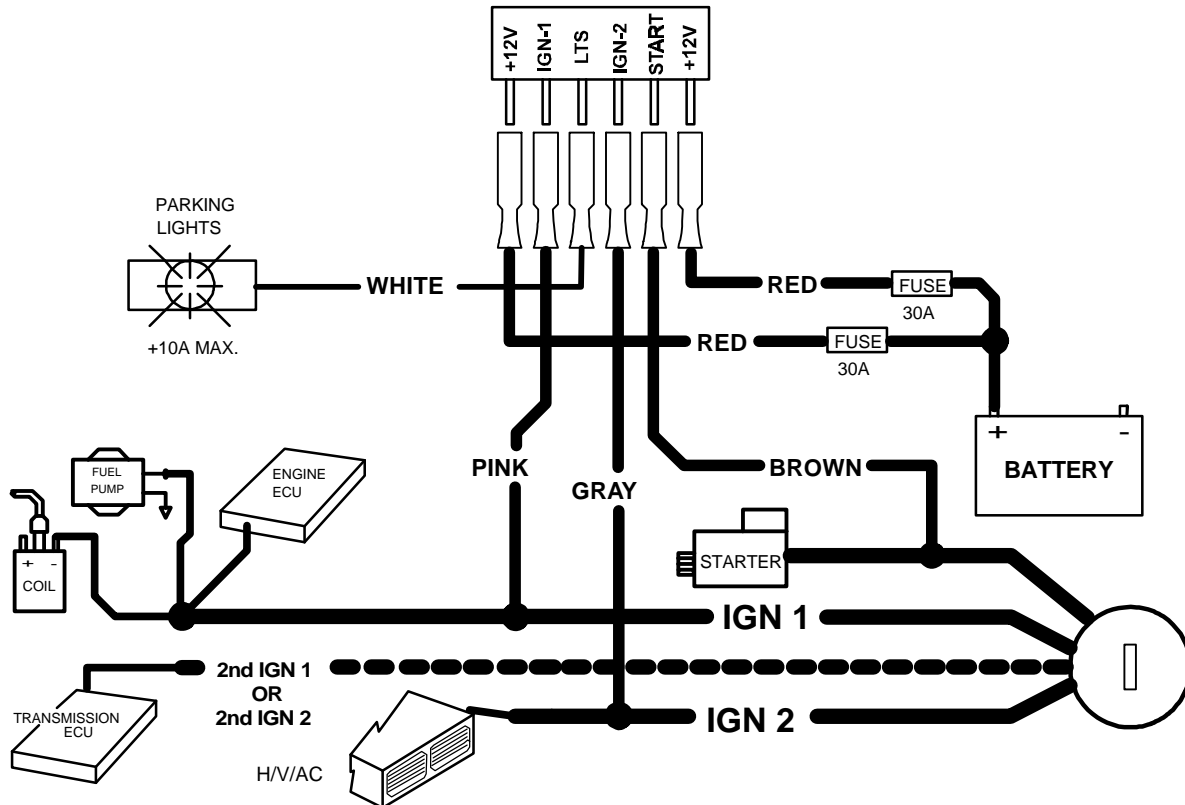

## SPADE PIN 4: WHITE: (+) PARKING LIGHT OUTPUT [10 AMP MAX.]

(WHITE OUTPUT WIRE MUST BE FUSED OR SERIOUS DAMAGE MAY OCCUR.)

On most AMERICAN and JAPANESE vehicles, the parking lights will operate on a single fused circuit. You may connect WHITE wire directly to the wire of any parking light or at main lighting switch.

**NOTE:** Some JAPANESE vehicles use a negative triggered relay to activate parking lights. Use a relay to convert to ground switch or tap into the positive circuit of the parking lights after the Factory relay. On most EUROPEAN vehicles, the light circuits are separately fused for left and right. Each circuit must be individually connected and isolated from one another. This can be done by using two(2) 6A05 6 Amp diodes, OR one(1) BOSCH SPST dual output relay(part no. 0-332-015-001).

# POWER DOOR LOCK WIRING

## 3 PIN DOOR LOCK PLUG:

### PIN 1: GREEN:

Sends a (-) Negative pulse for LOCK; Sends a positive pulse for UNLOCK

### PIN 2: RED:

+12V Coil Power for external relays TERM 86. (If needed.)

### PIN 3: BLUE:

Sends a (-) Negative pulse for UNLOCK; Sends a positive pulse for LOCK

## DETERMINING DOOR LOCK TYPE:

**WARNING:** You must determine the type of locking system the vehicle has before connecting any wires. Incorrect connection will result in damage to the remote start and/or vehicle locking system. Use 1 amp diodes as shown in the diagram below when tapping into a Factory Positive or Negative door lock system to protect the output transistors against a dead short from some types of Factory locking systems.

There are several types of door lock systems in vehicles today. Below is listed the many types of common locking systems:

**Negative trigger:** Most Japanese; Ford, New GM

**Positive trigger:** Many GM; Some Dodge/Chrysler/Plymouth

**One wire dual voltage:** Newer Dodge/Chrysler/Plymouth; Ford Probe

**Reverse Polarity:** Dodge/Chrysler/Plymouth; GM; Ford

**Ground/open:** Some Nissan; Subaru

**Semi-automatic:** Older Saab and Volvo

**Electric vacuum pump:** Pre 1995 Mercedes-Benz

## DOOR LOCK DIAGRAMS WITH FACTORY RELAYS

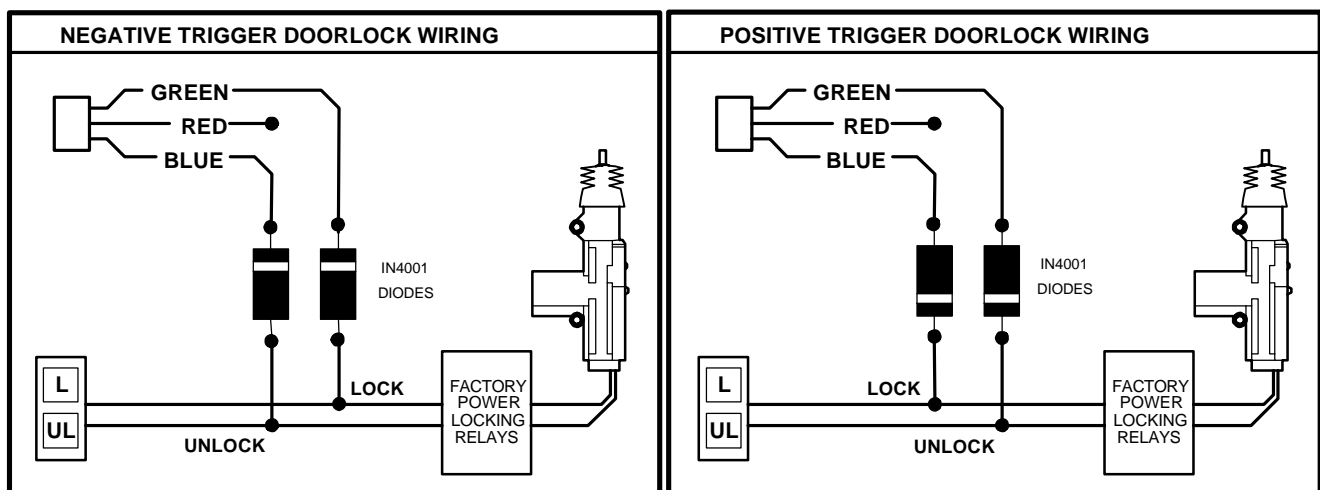

FOR ADDITIONAL DIAGRAMS - SEE PAGE 11

# TESTING FOR REVERSE POLARITY DOOR LOCKS WITH A VOM

(5 wire switch)

Reverse Polarity Door Lock Systems are a series circuit in which one switch serves as a "master" source for the motor grounds. When any switch in the circuit is pressed, one of the grounds is "lifted" and voltage is applied to the open circuit causing the locks to activate.

**Set meter to VOLT scale sufficient to measure up to 15 volts.**

**Connect RED meter probe to constant +12 volt source.**

**Locate the door lock wires in either the driver's or passenger's kick panel. Use the BLACK probe of the meter check the wires one at a time:**

Common Wire Colors: (Use as a guide only, your vehicle may differ.)

FORD / LINCOLN MERCURY	DODGE / CHRYSLER PLYMOUTH	GENERAL MOTORS
Pink/Lt. Green	Orange/Violet	Lt. Blue
Pink/Yellow	Pink/Violet or Orange*	Dark Blue or Black
	Pink*	Black/White (Trucks)
		Black/Red (Trucks)

\*There may be (2) wires of the same color

Connect meter to first wire, meter should read about 12 volts. Press the LEFT door lock switch to the lock position, then unlock position. Now press the RIGHT door lock switch to the lock, then unlock positions. If BOTH SWITCHES make the wire read 0 volt, it is the WRONG WIRE (it's a motor wire). TRY ANOTHER WIRE. If ONLY ONE SWITCH makes the meter read 0 volt, then it is the CORRECT WIRE and that switch is the "MASTER". When meter reads 0 Volts when LOCK is pressed, that wire is the LOCK wire. If Meter Reads 0 Volts when UNLOCK position is pressed, that wire is the UNLOCK wire. REMEMBER - CORRECT WIRES will show 0 volts from ONLY 1 SWITCH. Repeat the test procedure above for second wire.

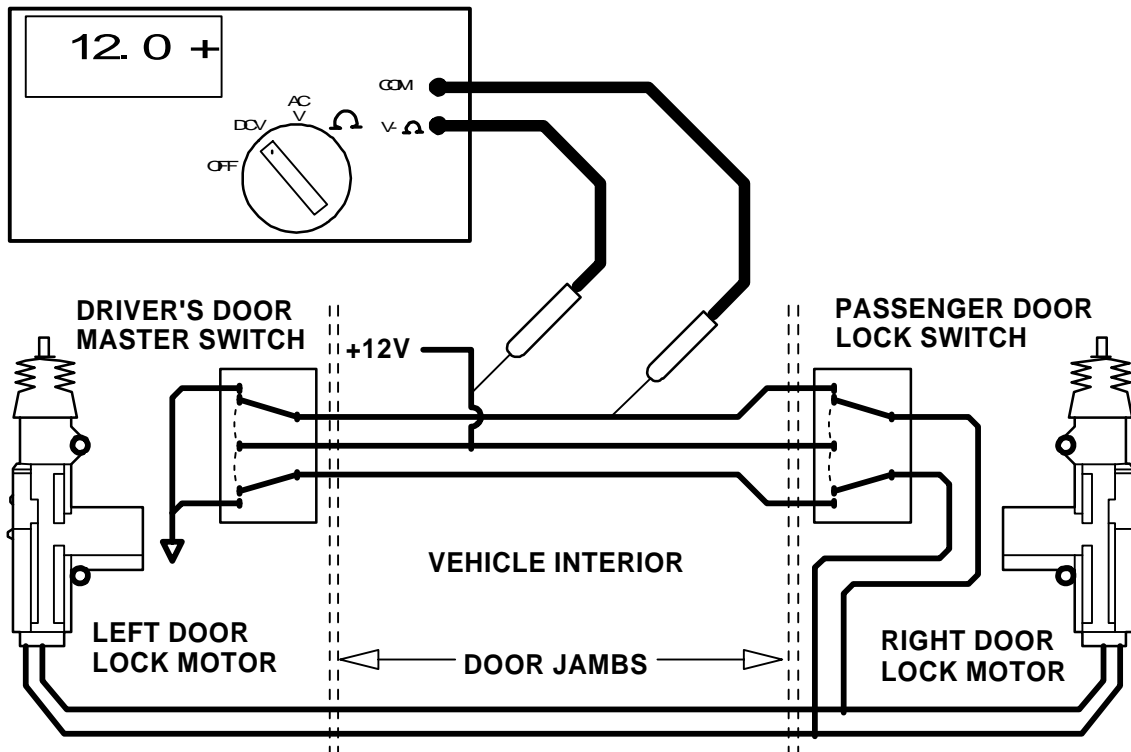

# POWER DOOR LOCK WIRING DIAGRAMS

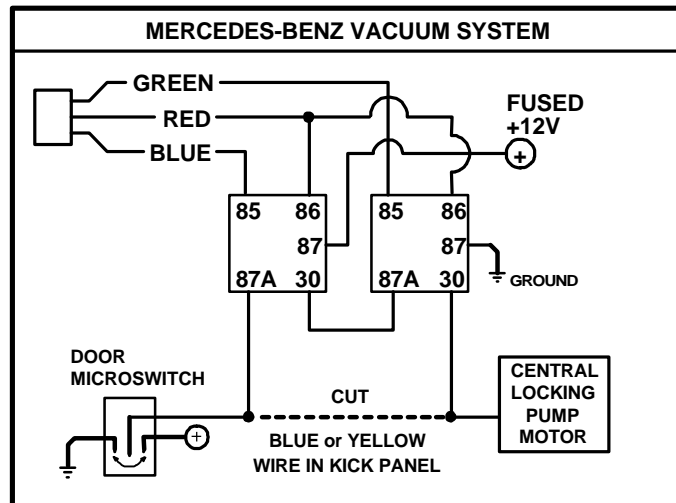
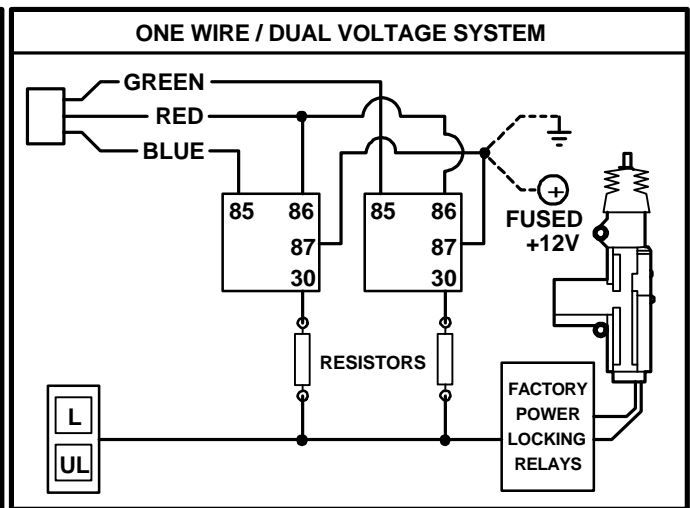
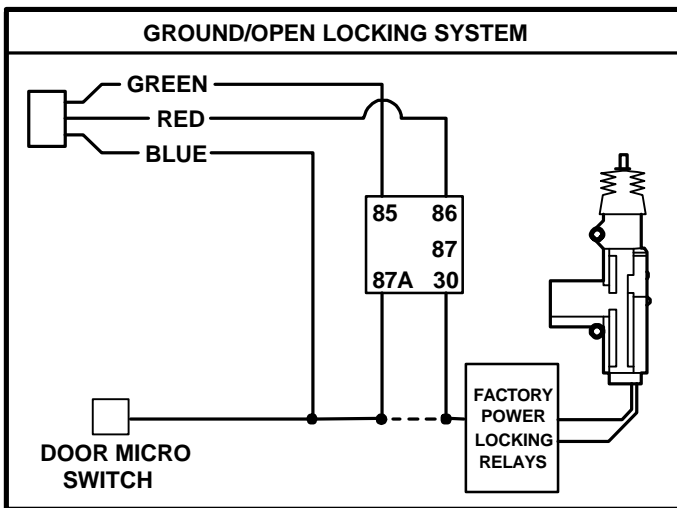
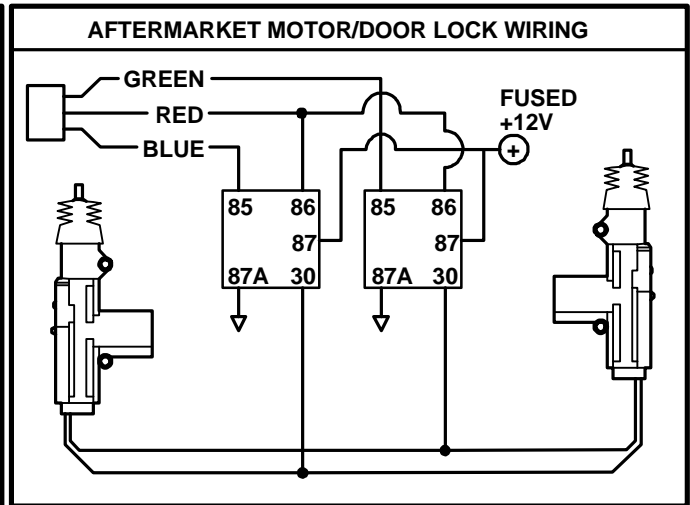
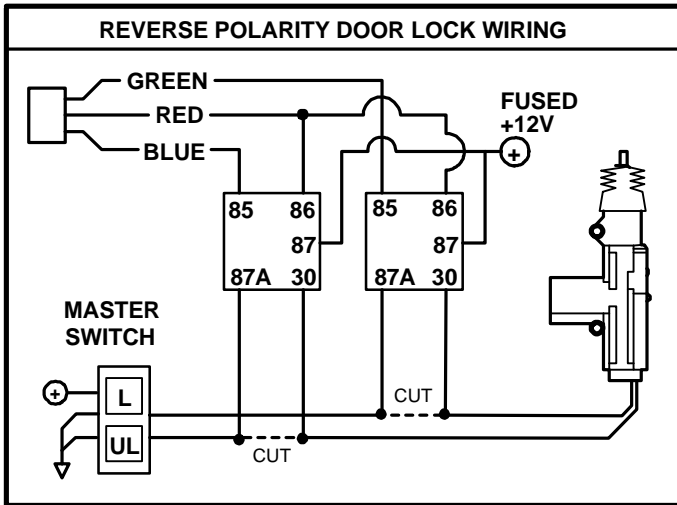

# PROGRAMMING

## CODE LEARNING PROGRAMMING:

The RS900ER will learn up to 4 different transmitter security codes. This procedure does not apply to the RS901 add-on Remote Start module.

## Transmitter Programming:

- 1) Open Hood(Gray wire grounded).
- 2) Depress and Hold BRAKE PEDAL, and then Press Program Button until parking lights turn ON solid.
- 3) Release program button.
- 4) With BRAKE Depressed, Press and Hold program button again.
- 5) Within 4 seconds press any button on transmitter.
- 6) Parking lights will flash once to confirm programming. Release Remote and Program button after confirmation.
- 7) CLOSE HOOD FIRST, Then press and release BRAKE PEDAL to clear parking lights.

## Tach Reference Programming:

- 1) Open Hood(Gray wire grounded), Start Engine.
- 2) Depress and Hold BRAKE PEDAL, and then Press Program Button until parking lights turn ON flashing. (*Tach-Finder mode is now engaged*).
- 3) Release program button.
- 4) With BRAKE Depressed, Press and Hold program button again, Parking lights will be on solid (not flashing). Tach reference is now learned.
- 5) Release Program Button, Parking Lights will begin flashing again.
- 6) CLOSE HOOD FIRST, Then press and release BRAKE PEDAL to clear parking lights.

## Programmable Options:

This system has several installer programmable features. Below is a brief description of these features.

### Option #1 - Crank Time:

This programs the amount of time the starter cranks. This programming works ONLY when Option #2 (Engine Sense) is programmed to Value 2 (Timed Crank).

### Option #2 - Engine Sense:

This programs the TYPE of Engine monitoring the system uses. Value 1 (Tach sensing) is the most reliable and accurate. Value 2 (Timed Crank) is for "Semi-Tachless Mode" when there is only poor or dirty tach signals that cannot be cleaned up. Value 3 (Vacuum) This requires installing an additional Vacuum Switch.

### Option #3 – Remote Auxiliary Output:

This programs the remote output of the system for activating a trunk release. Value 1 is No Output. Value 2 enables the output to operate on Multi-Function Output Wire #2 (Orange wire). Value 3 enables the output to operate on Multi-Function Output Wire #1 (Tan wire).

### Option #4 - Double Unlock Pulse:

Programs UNLOCK Pulse to be either a single or double pulse. Makes the installation into vehicles such as Nissan's and Volkswagens that require an additional pulse for Factory DISARM very easy.

### Option #5 - Lock after Remote Start TIME-OUT or ABORT:

Programs system to re-lock power door locks after remote engine start turns off. This is to ensure that vehicles which come equipped with factory ignition controlled door locks will not leave the vehicle unlocked. (Many GM's such as Buick)

### Option #6 – Run Time:

Program the desired run time for remote start. The programmed run time also applies to the Idle-Down feature. Value 1 is 10 min., Value 2 is 20 min., and Value 3 is 40 min.

**SEE PROCEDURE and CHART on NEXT PAGE for EASY OPTIONS PROGRAMMING.**

# PROGRAMMING

## Options Programming:

- 1) Open Hood (Gray wire grounded) Depress and Hold BRAKE PEDAL.
- 2) Press and Release program button. (Parking lights come on.)
- 3) Wait 2 seconds, then press and release brake pedal again.
- 4) Release BRAKE PEDAL
- 5) Momentarily Press then Release program button the number of times for the option program level desired. Parking lights will flash the same number of times to confirm the program level.
- 6) Press then Release BRAKE PEDAL to increment the option value. Parking Light flashes will equal Option Value setting to confirm programming.
- 7) When finished programming, CLOSE HOOD FIRST, Then press and release BRAKE PEDAL to clear parking lights.

## PROGRAMMING OPTIONS CHART

Prog. Level	Option Description	Option Values	Fac. Pre-set
#1	Crank Time (in seconds)	1 = 0.75 sec. 2 = 1.25 sec. 3 = 1.75 sec. 4 = 2.25 sec.	1
#2	Engine Sense	1 = Tach 2 = Timed Crank 3 = Vacuum	1
#3	Remote Aux. Output	1 = Not Active 2 = Directed to Orange 3 = Directed to Tan	1
#4	Door Unlock Pulse	1 = Single Unlock Pulse 2 = Double Unlock Pulse	1
#5	Lock After R.S. Time/Out (Abort)	1 = Disabled 2 = Enabled	1
#6	Run Time	1 = 10 Min. 2 = 20 Min. 3 = 40 Min.	2

## EXAMPLE:

### Program Remote Aux. output (Trunk Pop) channel to TAN Multi-Function wire.

- 1) Open Hood. Depress and Hold BRAKE PEDAL.
- 2) Press and Release program button. (Parking lights come on.)
- 3) Wait 2 seconds, then press and release brake pedal again.
- 4) Release BRAKE PEDAL
- 5) Momentarily press then Release program button 3 times. Parking lights should flash 3 times.
- 6) Press BRAKE PEDAL twice to get from option value #1 (default) to Option value #3. Parking Lights will flash 3 times to confirm you are at option 3.
- 7) Close hood, then press brake pedal to clear.
- 8) The TAN wire should now be a negative output when the Trunk (#3) button on Transmitter is pressed for 1 second or longer.

