

***RS800ER / RS801***  
**REMOTE ENGINE STARTING SYSTEM**  
**INSTALLATION INSTRUCTIONS**

**PRE-INSTALLATION CONSIDERATIONS**

To ease and reduce installation time, we suggest you consider the following points before starting:

1. Determine most suitable locations for all components to be placed. These components include: The module itself, valet/program button, possible extra relays, and antenna/receiver (RS800 Model Only).
2. Allow enough wire to create a service loop with strain relief, should servicing be required. This will also allow easier access and mounting.
3. Use a Volt/Ohm meter to test and locate all connections. Test Lights can damage a vehicle's computer systems.
4. Record all color codes of vehicle wiring to be used for reference. This will save time by not having to re-test the same wires over again.
5. Additional Parts, which are not included with this unit, may be needed for your particular vehicle. These items may include extra relays, Anti-Theft Bypass modules, or Transponder Bypass modules.

**TECHNICAL SUPPORT: 1-800-998-6880**

Monday - Friday 8:00am - 4:30pm Pacific Time

Web Site: [www.crimestopper.com](http://www.crimestopper.com)

E-mail: [tech-support@crimestopper.com](mailto:tech-support@crimestopper.com)

CRIMESTOPPER SECURITY PRODUCTS, INC.  
1770 S. TAPO STREET, SIMI VALLEY, CA. 93063

This device complies with FCC Rules part 15. Operation is subject to the following two conditions: (1) This device may not cause harmful interference, and (2) This device must accept any interference that may be received, including interference that may cause undesired operation. The manufacturer is not responsible for any radio or TV interference caused by unauthorized modifications to this equipment. Such modification could void the user's authority to use the equipment.

## INSTALLATION CAUTIONS & WARNINGS

**\*\*FOR SAFETY REASONS, DO NOT INSTALL RS800/801 in vehicles with MANUAL TRANSMISSIONS.\*\*** If accidentally left in gear, a remote started vehicle could become a self-propelled threat to life and property.

**WARNING:** This system does NOT have engine over-rev protection. Make certain vehicle throttle linkage operates properly and does not stick. A stuck throttle will cause severe engine damage

**DO NOT** extend the RS800/801 Remote start ignition harness length. Mount the module so that main harness reaches all ignition switch wiring. Extending these wires could result in poor performance.

**DO NOT** route any wiring that may become entangled with brake, and gas pedals, steering column, or any other moving parts in the vehicle.

**DO NOT** exceed the rated output current of any circuit on the Remote start module. Failure to observe this warning will result in damage to the unit and/or create a hazardous condition in the vehicle.

**DO NOT** remote start the vehicle in a closed garage. Make sure that the garage door is open or there is adequate ventilation. Failure to observe this rule could result in injury or death from poisonous Carbon Monoxide fumes.

## WIRING INSTRUCTIONS

### **2 PIN PLUG-PROGRAM/OVERRIDE SWITCH:**

This switch is used for programming features, transmitters, valet mode, and must be used to override the Starter Disable (if optional feature installed) in the event of a non-operating remote control.

### **2 PIN PLUG-LED:**

The LED is used as an indicator for Valet, Programming, and for use as security deterrent with the optional ANTI-GRIND/STARTER DISABLE feature installed. Mount in a visible location on the dash or in the console.

### **PIN 1 & 2: YELLOW / YELLOW/WHITE: (-) IGN / (-) ACC OUTPUTS (FOR ADDING RELAYS)**

Use these wires when the vehicle requires a second IGNITION or ACCESSORY circuit to be activated. This occurs on Toyota, late GM, and other models of vehicles. This wire is also used to turn on ANTI-THEFT or TRANSPONDER Bypass Modules. Connect to the "ground when running" input of the bypass module. (See Diagram on NEXT PAGE.)

### **PIN 3: BLACK: MAIN SYSTEM GROUND**

Connect to chassis metal of the vehicle. An existing bolt or screw MAY provide an adequate ground, or drill a small hole, scrape away paint and attach using a sheet metal screw & star washer. This wire MUST be connected to a good ground or undesirable and inconsistent operation will occur.

# WIRING INSTRUCTIONS

**YELLOW / YELLOW/WHITE (-) IGN. & (-) ACC. OUTPUTS (GROUND WHEN RUNNING):**

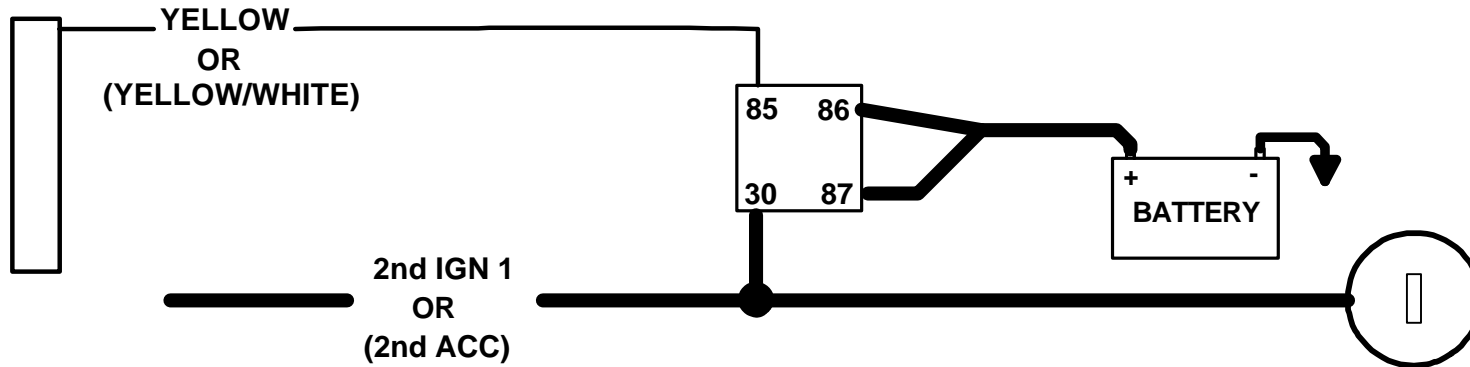

## **PIN 4: YELLOW/BLACK: (-) ANTI-GRIND/STARTER KILL OUTPUT (OPTIONAL)**

Use this wire for the negative side of the Anti-Grind/Starter Disable relay. It can also be used as a sensor disable circuit for a host alarm for an RS801 installation. This output activates whenever a remote start is requested, and when the vehicle is remotely locked with the transmitter. The output can also be programmed to activate passively. (See diagram)

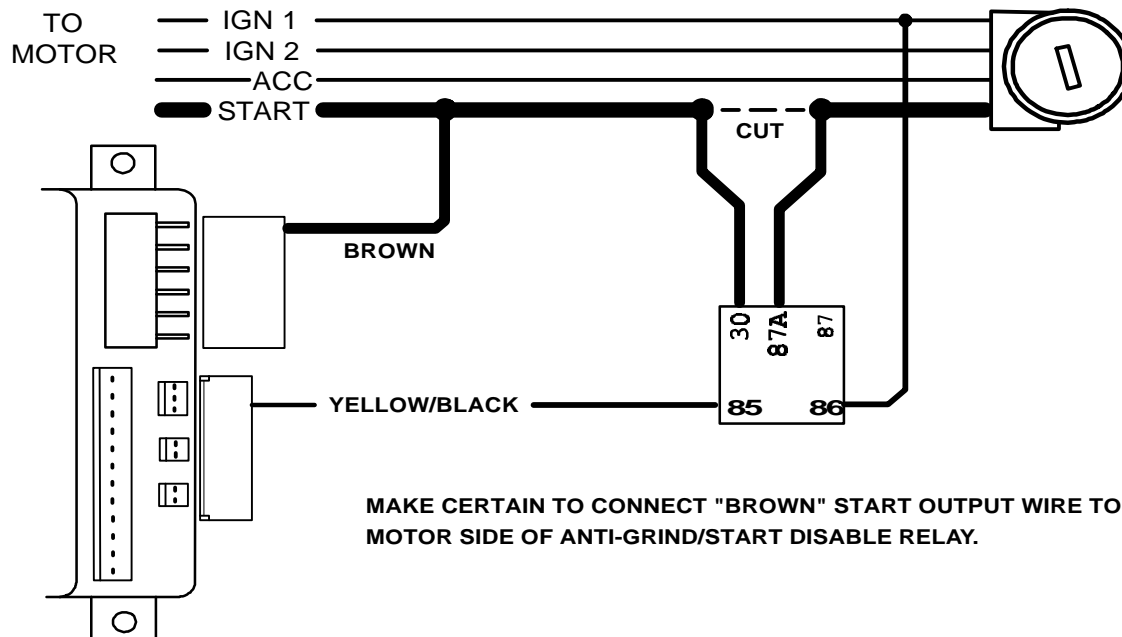

# WIRING INSTRUCTIONS

## **PIN 5: EMPTY (NOT USED)**

## **PIN 6: GREEN: RS801 START ACTIVATION (-) TRIGGER INPUT**

This wire allows the Auxiliary Channel Output of a separate (host) Alarm or Keyless Entry System to activate a Remote Start when installing the RS801 model. A 1 second (-) Negative pulse on the Green wire will trigger/stop a remote start.

## **PIN 7: GRAY: (-) HOOD PIN SWITCH**

Connect the Gray wire to a switch that is at ground when the hood is open. If an existing switch is not available, then one must be installed. When this wire is grounded, the remote start is inhibited. If hood is opened on a remote started engine, the unit will immediately shut the motor off. If hood is open before a remote start unit will not attempt to start engine.

## **PIN 8: PINK: (+12V) DIESEL GLOW PLUG INPUT**

Connect Pink wire to indicator circuit that shows +12 volts while the "WAIT TO START LAMP" is on. When this wire is used, the RS800/801 will wait until light turns off before attempting a remote start. Note: For vehicles that have a Negative Wait to Start lamp An extra relay may be required.

## **PIN 9: PURPLE: (+12V) BRAKE RESET**

Connect the Purple wire to the side of brake pedal switch that shows +12 volts ONLY when pedal is depressed. This will turn off the remote start if someone attempts to drive the car without the keys or if the Ignition key is not turned on all the way.

## **PIN 10: ORANGE/BLACK: (-) OEM DISARM OUTPUT**

This wire provides a Ground pulse to disarm the vehicles' Factory anti-theft system prior to a Remote Start. Connect this wire to the vehicles' anti-theft disarm wire. This wire is sometimes found coming off the Driver's door key switch or at the Factory Anti-theft control module. This wire may not be needed if Factory Security only requires a door unlock pulse.

## **PIN 11: ORANGE: (-) OEM REARM OUTPUT**

This wire provides a ground pulse to rearm the vehicles' FACTORY anti-theft system after a timed-out or aborted remote start. Connect this wire to the vehicles' anti-theft rearm wire or to the door pin circuit depending on your requirements. This wire may be needed to pulse the door pin circuit on vehicles with retained accessory power.

## **PIN 12: RED/WHITE: TACHOMETER INPUT**

When installing the RS800/801 in TACH REFERENCE mode, this wire must be connected to a valid source of AC voltage. This wire allows the system to sense the engine speed (RPM) and control the starter motor.

# IGNITION SWITCH WIRING

## 6 PIN HIGH-CURRENT CONNECTORS:

- PIN 1: BROWN 14 GA.: STARTER OUTPUT (30A)**
- PIN 2: GRAY 14 GA.: ACCESSORY / IGNITION 2 (30A)**
- PIN 3: RED 14 GA.: BATTERY CONSTANT FUSED (30A)**
- PIN 4: RED 14 GA.: BATTERY CONSTANT FUSED (30A)**
- PIN 5: PINK 14 GA.: IGNITION 1 (30A)**
- PIN 6: WHITE 18 GA.: (+) PARKING LIGHTS (10A)**

**NOTE:** Heavy duty/High Current Ignition circuits greater than 30 AMPS, such as those found on Work or Industrial vehicles, require high-current relays. DO NOT use the outputs of the RS800/801 for High-Current systems or you will risk damaging the unit and creating a hazardous condition! Use Part #CS-403 relays for circuits up to 70 amps.

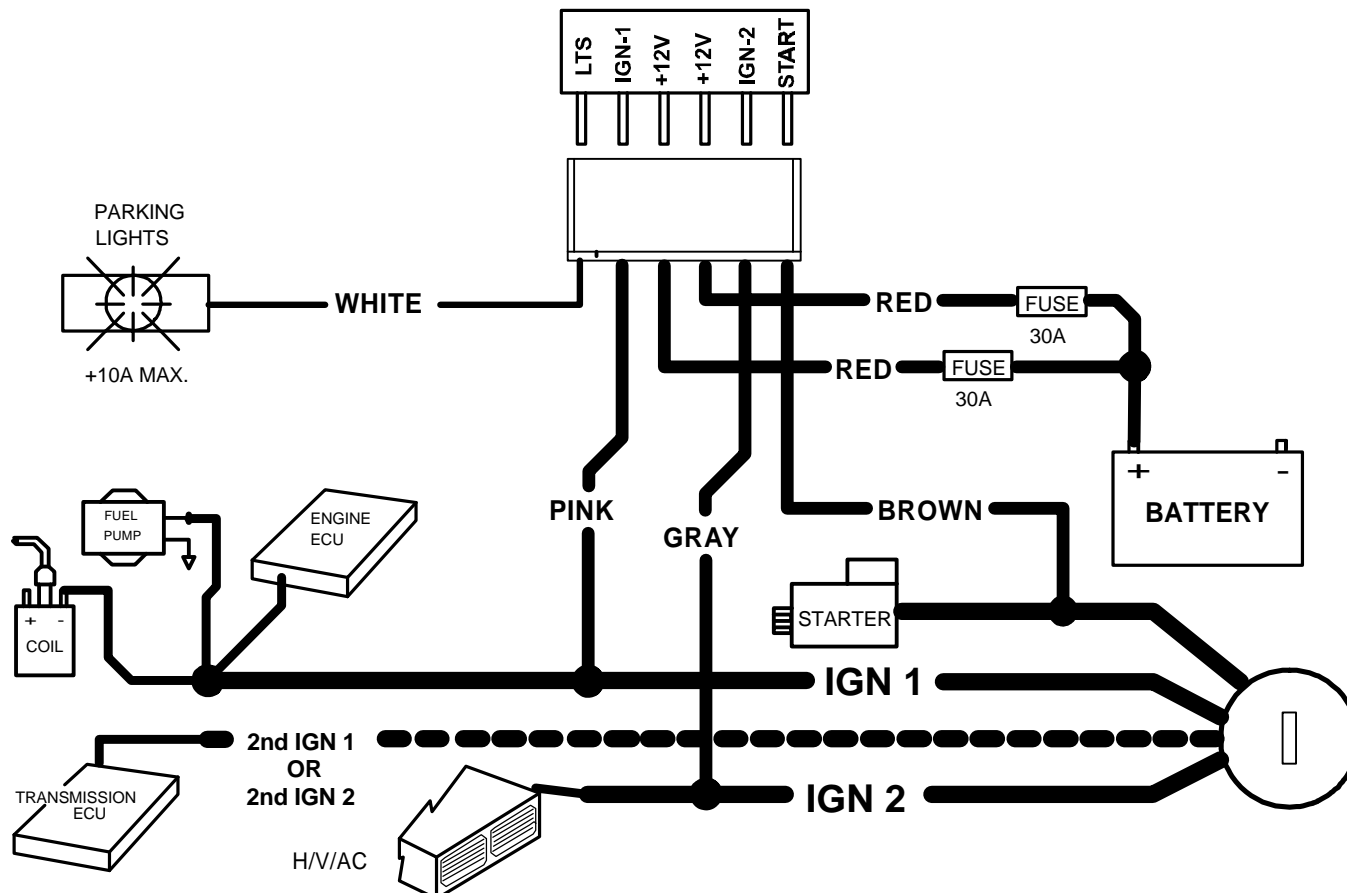

# POWER DOOR LOCK WIRING

## 3 PIN DOOR LOCK PLUG:

**PIN 1: GREEN:** (-) Negative pulse for LOCK

**PIN 2: RED:** +12V Coil Power for external relays TERM 86.

**PIN 3: BLUE:** (-) Negative pulse for UNLOCK

**DETERMINING DOOR LOCK TYPE:** We recommend determining the type of locking system the vehicle has before connecting any wires. Incorrect connection will result in damage to the remote start and/or vehicle locking system. There are several types of door lock systems in vehicles today. Below is listed the many types of common locking systems:

**Negative trigger:** Most Japanese; Ford, New GM

**Positive trigger:** Many GM; Some Chrysler

**One wire dual voltage:** Newer Chrys/Dodg/Plym; Ford Probe

**Reverse Polarity:** Chrys/Dodg/Plym; GM; Ford

**Ground/open:** Some Nissan; Subaru

**Semi-automatic:** Older Saab and Volvo

**Electric vacuum pump:** Pre-'95 Mercedes-Benz

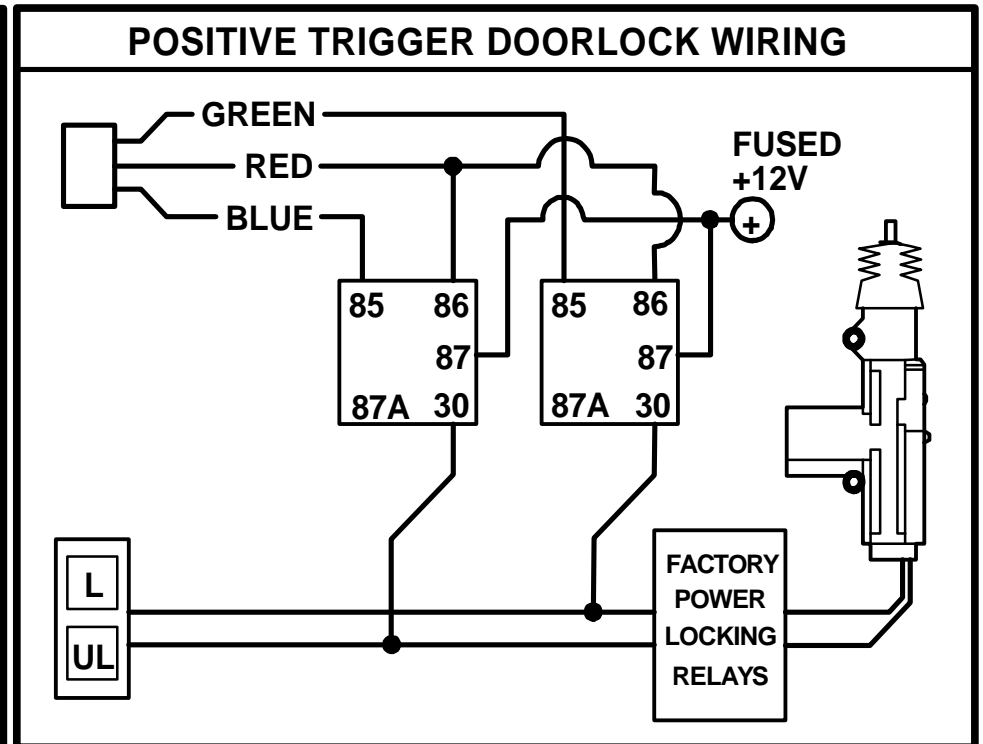
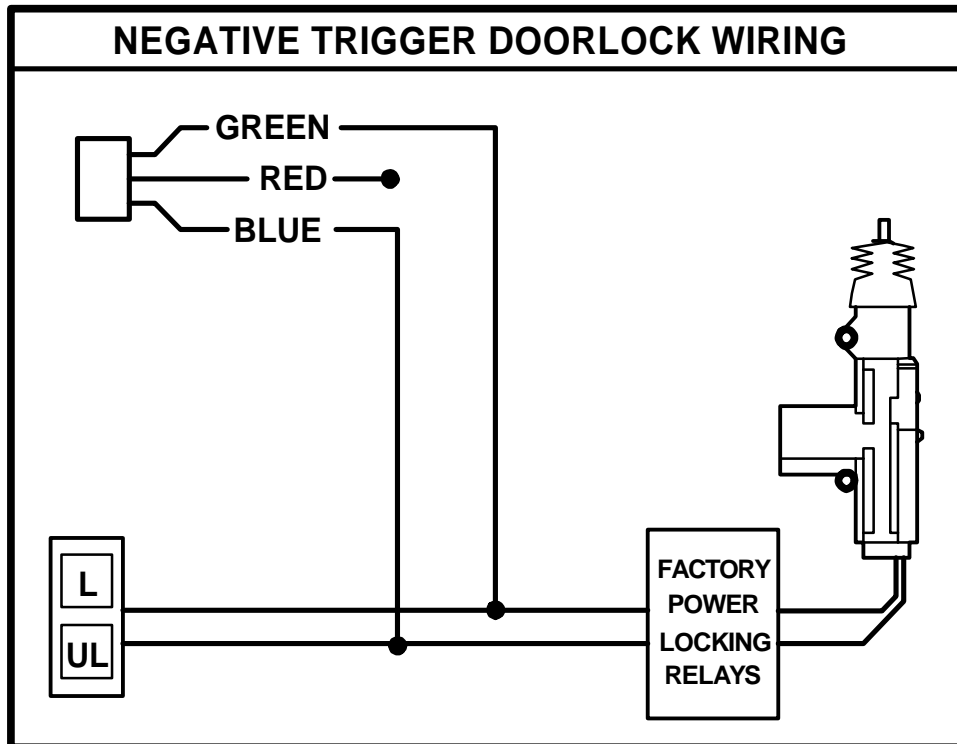

# POWER DOOR LOCK WIRING

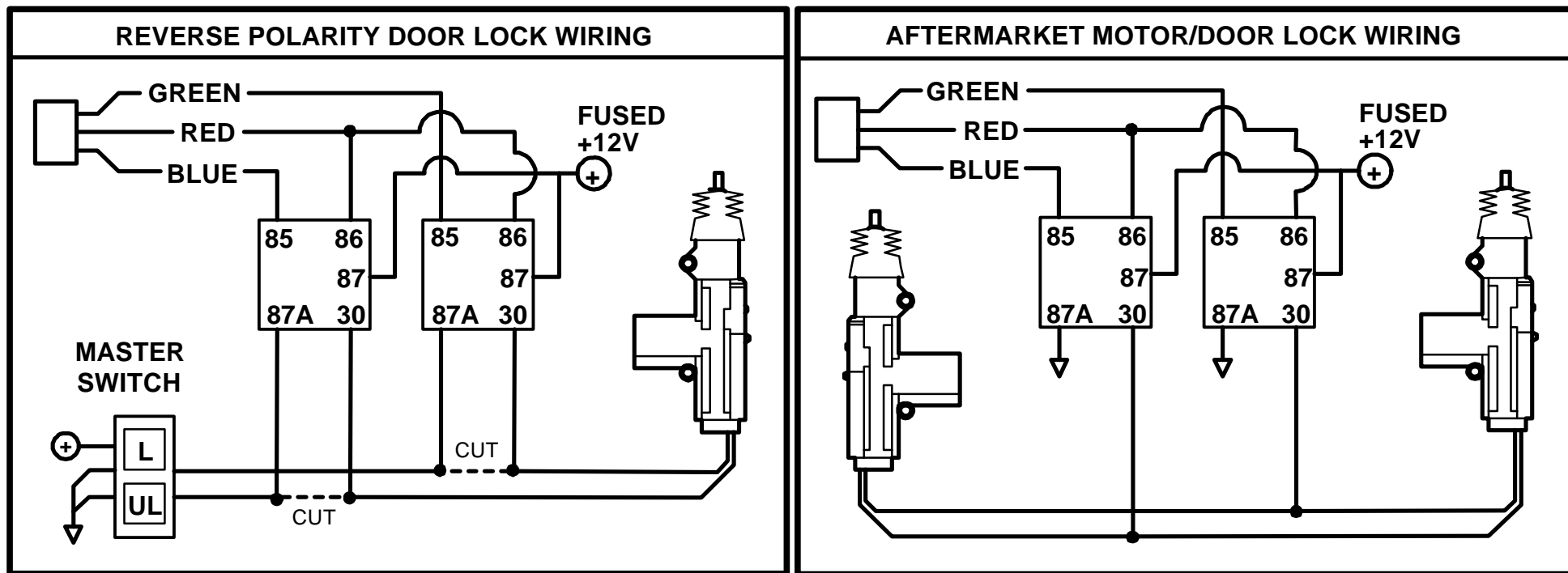

## “SMART” TACHLESS MODE

This RS800 includes custom monitoring circuitry allowing the unit to start an engine without the use of a Tach Wire. The module actively monitors the vehicle over the life of the installation regardless of weather or battery conditions. The “Smart” Tachless Mode circuitry allows the remote start system to compensate for most conditions over life of the vehicle while adjusting by itself for optimum starting capabilities.

**IMPORTANT NOTE:** Vehicles with more than one battery may give out inconsistent voltage readings. This may result in poor performance when using “Smart” Tachless Mode. Use a Tach wire and program a Tach source when installing an RS800/801 on vehicles using 2 [or more] Batteries.

### TO SET SMART TACHLESS MODE: (No Tach Wire Required)

- 1) DO NOT START VEHICLE! Turn IGN ON, turn HEADLIGHTS ON and FAN BLOWER ON HIGH for 2-3 minutes to drain off excess surface charge on the vehicle’s battery.
- 2) After 2-3 minutes, connect the (2) RED +12V input wires to the Module.
- 3) The unit will automatically read and program itself for your vehicle when voltage is applied.

## “SMART” TACHLESS MODE

### **SMART TACHLESS JUMPERS: (Remove Access Door on top of module)**

The purpose of the jumpers is to reduce the starter cranking time [if needed] when in “**Smart Tachless**” mode only.

**PIN ORIENTATION:** Looking at remote start upright with harnesses facing down (or towards you).

To shorten the crank time one level, remove the jumper at the far right. Test the unit and see if the decrease is correct. If a shorter crank time is still required, then remove the middle jumper. Test the unit and see if the decrease is correct. There are only (2) adjustments. Removing the third jumper will not make any change to the crank time. These (2) setting should correct most cranking times when in Smart Tachless mode.

### **IMPORTANT SMART TACHLESS NOTES:**

**NOTE (1):** Smart Tachless Mode is NOT guaranteed to work on EVERY vehicle. Some older vehicles, Dual-Battery Systems, or Out-of-Tune vehicles will not operate properly in Smart Tachless Mode. Use Tach Reference Mode if problems occur with Smart Tachless Mode

**NOTE (2):** If you have connected the RED power lines before performing steps for “Set Smart Tachless Mode”, the RS800/801 will not have the correct voltage reference for your vehicle. If this is the case, power down the unit and perform those steps.

**NOTE (3):** If you have changed battery in the vehicle, wait 2 hours before attempting a remote start or follow the steps for “Set Smart Tachless Mode” again.

## TACH REFERENCE MODE

**Tach Reference Mode:** This mode provides reliable starting performance through engine speed sensing. When using this mode, the WHITE/RED wire provides the signal input for the RS800/801 system to monitor the engine and control the starter motor. Most modern engines include various points where the Engine Speed signal may be obtained. TACH SIGNAL EXAMPLES: Negative (-) side of ignition coil, at the Distributor, at the Ignition Control Module, a Coil Pack, Engine Computer, or Crankshaft Sensor. Sometimes Fuel injection solenoids, and Alternator stator pins can be used.

**Note:** *The Tach Signal locations above are provided as a guide, your vehicle may differ. Some locations will NOT be a good location for Tach source due to RF noise or Computer Data. The RS800/801 may not detect a clean signal. Call Crimestopper for Tech Support if you cannot locate a proper tach source for your vehicle.*

## TACH REFERENCE MODE

### TACH REFERENCE PROGRAMMING:

1. Open hood (Gray wire must be grounded).
2. Connect WHITE/RED wire to a valid Tach source.
3. Start engine with key.
4. Press program button 5 times, then wait for 5 light flashes.
5. Wait at least one second then push program button slowly (4) times, you should get a light flash after each button press. This unit is now at option #4-Tach Learning.
6. A) RS800: Press Button #1 remote transmitter. The unit will read the Tach source and flash the lights twice for program confirmation.
6. B) RS801: (No Remotes) Press the brake pedal to program the Tach Source.
7. If lights do not flash twice for confirmation, then try another tach source and repeat Steps 1-6 above.

***NOTE: The RS800/801 will operate in "Smart" Tachless Mode [by default] unless a Tach Reference has been programmed. When a Tach Reference is programmed, this automatically takes the unit out of "Smart" Tachless" Mode.***

### FAIL SAFE PROTECTION:

If the WHITE/RED TACH input wire becomes disconnected due to wear and tear or when the vehicle is serviced, the RS800/801 will automatically go into "Smart" Tachless" mode to allow the unit to continue starting the engine.

## TRANSMITTER PROGRAMMING (RS800ER ONLY)

### Transmitter Code Learning:

***Note: All transmitter codes must be learned at time of programming!! The RS800 allows storage of up to 4 different transmitter codes.***

1. Open Hood. (Ground Gray wire.)
2. Turn key to the ON position.
3. Press Programming button 4 times, then after a few seconds the unit will flash the parking lights 4 times.
4. Press button #1 of the transmitter to be coded. You should get 2 light flashes indication the unit is waiting for a 2<sup>nd</sup> code, then press button #1 of a second transmitter, the unit will flash 3 times indicating its waiting for the 3<sup>rd</sup> code and lights will flash 4 times for 4<sup>th</sup> code. If all 4 codes are learned, the unit will automatically exit code learning mode, otherwise turn key OFF and close hood.

# OPTION PROGRAMMING

This system has several installer programmable features as listed in the chart below.

## Option Programming:

1. Open hood (Gray wire grounded)
2. Turn Key to the ON position
3. Press program button 5 times, after a few seconds the unit will flash the lights 5 times.
4. Push the valet/program button [again] the number of times that corresponds to the option number desired. You should get a light flash after each button press.
5. A) **For RS800:** When you reach the desired programming level, Press button #1(Lock) or #2 (Start) to change the option. See the chart below for option values and descriptions. See chart below.
5. B) **For RS801:** (No remotes) Tap the brake pedal once to change the option (Same as pressing Button 1 on a remote). To reset the option back to Default, tap the brake pedal 2 times (Same as pressing Button #2 on a remote)
6. Turn Ignition OFF, Close hood and check for changed features. Change each option individually repeating STEPS 1-5 above.

## OPTIONS CHART

Option #	Option Description	Option Values	Button #1 LOCK	Button #2 START (Default)
1	NOT USED	NOT USED		
2	Door Lock Pulse Time	0.75 Sec. (Standard) OR 3.0 Sec. (European Vacuum)	3 Sec.	0.75 Sec.
3	Double Unlock Pulse	ON or OFF	ON	OFF
4	Tach Learning	See Tach Reference Programming	Learn Tach	
5	Remote Start Engine Run Time	Button #1 = 48 Min. Button #2 = 24 Min.	24 Min.	36 Min.
6	Option reset	Button #2		Reset ALL to Default

# REMOTE START TROUBLESHOOTING

## ***UNIT FLASHES LIGHTS ONCE AND WILL NOT ATTEMPT A START:***

The unit is in Valet mode. Turn IGN ON, press and hold valet/programming button for about 4 seconds until LED goes out. The unit is now out of valet mode and should perform a remote start.

## ***UNIT FLASHES LIGHTS TWICE AND WILL NOT ATTEMPT A START:***

The unit reads a fault at the Brake (Purple wire is active) or the Hood is OPEN (Gray wire grounded). This is a safety feature of the unit. Check installation for faults and make sure hood is closed and latched.

## ***“SMART” TACHLESS MODE:***

### ***UNIT LIGHTS UP, PAUSES, AND ONLY SLIGHTLY ENGAGES STARTER (NOT ENOUGH TO START VEHICLE)***

The unit does not have the correct voltage reference for the vehicle. Unplug main Wire Harness (heavier gauge wires) on the remote start module, turn the key ON, the lights ON and the fan blower on HIGH for 2-3 minutes. Reconnect remote start module.

### ***UNIT CRANKS VEHICLE BUT ENGINE NEVER STARTS: (2 parts)***

1. In some vehicles, there may be a Factory anti-theft system that will not allow the engine to run without the key in the ignition. These systems may include Factory Security Modules, GM Passkey®/Passlock®, and RF Transponder systems (Ford P.A.T.S.®). Many late 90's and 2000-UP vehicles include some type of Anti-Theft systems, even on base or low-level models.
2. The vehicle may have more than one Ignition/or Accessory circuit that requires power for the vehicle to start. This is common on some GM/Toyota vehicles.

### ***VEHICLE STARTS BUT CHECK ENGINE LIGHT COMES ON OR ENGINE RUNS BADLY: (2 parts)***

1. Many 90's GM Cars/Trucks require a secondary ignition circuit for the Transmission computer. If the vehicle is starter without this wire energized the vehicle will display a “Check Engine” or “Service Engine” indicator on the dash. Caution: This may cause transmission damage if the vehicle is driven! Be sure to check for and additional WHITE (or sometimes GREEN) Ignition wire on GM cars and trucks.
2. Some Vehicles (Commonly Nissan) require 2 Start (Cranking) circuits for the vehicle to run properly. If this is the case, then an additional relay must be installed (triggered off of the BROWN start output wire). Connected to the Extra start relay output to the extra start wire in the vehicle.

### ***NO RESPONSE FROM EITHER TRANSMITTER: (RS800ER Only, 4 Parts)***

1. Check for proper power/ground wiring connections.
2. Check Antenna Module connection. The antenna module included with this system must be plugged in to allow the unit to send/receive signals.
3. The Remote Transmitters may need to be reprogrammed to operate the system. See Transmitter programming.
4. Remote Transmitters may be damaged or need new batteries.

