

# CS-2002DC

## REMOTE CONTROL ALARM SYSTEM INSTALLATION & OPERATING INSTRUCTIONS

---

### INTRODUCTION

**CONGRATULATIONS** on your choice of a Gargoyle™ Remote Alarm System by Crimestopper Security Products Inc. This system features DYNAMIC CODE anti code-grabbing technology. The remote control code changes with every use of the transmitter making it impossible to scan or record the codes for use later on. This booklet contains the information necessary for installing, using, and maintaining your alarm system. If any questions arise, contact your installation dealer or Crimestopper Security Products Inc. at the Tech Support number below.

**\*IMPORTANT INFORMATION: Primary and Optional Features**

**-PRIMARY:** These are features that must be connected in order for the system to operate properly i.e. Siren, L.E.D., Power, Ground, Doorpin, etc.

**-OPTIONAL:** These are features to be connected only if desired or agreed upon by the installing dealer (i.e. Door Locks, Flashing Lights, Starter Kill, Hood, Trunk, and Auxiliary Remote Outputs etc.)

**TECH SUPPORT**  
**Mon-Fri 8:00 AM-4:30 PM Pacific Time**  
**(800) 998-6880**

This device complies with FCC Rules part 15. Operation is subject to the following two conditions: 1) This device may not cause interference, and (2) this device must accept any interference that may be received, including interference that may cause undesired operation. The manufacturer is not responsible for any radio or TV interference caused by unauthorized modification to this equipment. Such modification could void the user's authority to operate the equipment.

## INSTALLATION CAUTIONS & WARNINGS

**BEFORE BEGINNING**, check all vehicle manufacturer cautions and warnings regarding electrical service (AIR BAGS, ABS BRAKES, AND BATTERY).

**TO PREVENT A POSSIBLE DEAD BATTERY** remove vehicle dome light fuse while working on the vehicle. MAKE CERTAIN TO REINSTALL FUSE PRIOR TO TESTING FOR DOOR TRIGGERS.

**DO NOT EXCEED MAXIMUM OUTPUT RATINGS! - SERIOUS DAMAGE MAY OCCUR. LIMITS FOR ALARM FUNCTIONS ARE LISTED WHERE APPLICABLE. IF UNSURE ABOUT CURRENT LOAD, MEASURE LOAD WITH AN AMP-METER.**

**REMOVE MAIN SYSTEM FUSE(S)** before jump starting the vehicle or charging the battery at high boost. DAMAGE MAY OCCUR TO SYSTEM IF PROPER PRECAUTIONS ARE NOT OBSERVED.

**DO NOT ROUTE ANY WIRING THAT MAY BECOME ENTANGLED** with brake, and gas pedals, steering column, or any other moving parts in the vehicle.

## CONTROL MODULE MOUNTING

***DO NOT Mount the control unit in the engine compartment.***

***DO NOT Mount the control unit or wiring harness where they can become entangled with moving parts such as brake/gas/clutch pedals, or the steering column.***

*The alarm control module should be mounted in a concealed location. The Placement of the module will affect the distance from which the remote transmitter can control the unit. The antenna wire should be routed away from any metal if possible. Do not alter the length of the antenna wire or route it with other wires. Do not ground the antenna wire.*

**Underdash Mounting:** If you are locating the control unit underdash, mount it as high as possible not easily located by an intruder.

**Driver's Side underdash** mounting provides an easy location for wiring however this is a common location for an intruder to check for an alarm after breaking into the vehicle. The left side of the vehicle may contain more metal and or wiring that will create interference and decrease the operating range of the system.

**Passenger Side underdash** is often the best location, however some extra wiring may be needed to extend wires across from the driver's side.

**Under-seat / Center Console** mounting is also a possibility however range be affected by metal structures and of the unit may be exposed to moisture from spilled drinks etc. Moisture or Damage caused by corrosion is not covered under warranty.

## COMPONENT MOUNTING

**SIREN MOUNTING:** Mount the siren under the hood to fender-well or other body surface with the open end facing downward. Run the red siren wire through the firewall using a rubber grommet. Ground the black wire to the body metal near the siren.

**LED:** Mount the red **LED** in a visible location on the dashboard or console.

**Shock Sensor:** Mount the included shock sensor with wire ties to an under dash wire harness or fasten with screws to firewall or side paneling.

**Override/Program Button:** Mount the **Override/Program** push-button in a hidden but accessible location. It is used for emergency disarm without the use of the transmitter and for programming certain features.

## WIRING

### **RED WIRE: +12V POWER INPUT (15 amp fuse)**

Connect to +12 Volt source with supplied fuse & holder. Recommended location for this connection is at the vehicle battery positive terminal.

### **BLACK WIRE: SYSTEM CHASSIS GROUND**

THIS WIRE MUST BE CONNECTED TO CHASSIS METAL OF THE VEHICLE. Scrape away any paint or dirt from the connection point to ensure a good connection. We recommend the kick panel area for your ground point.

### **YELLOW WIRE: IGNITION SWITCHED “ON” AND “START” +12 VOLTS**

Connect to an ignition wire (or fuse in the fuse box) that shows +12 Volts when the key in both “On” and “Start” positions.

### **ORANGE WIRE: STARTER KILL / NEGATIVE ARMED OUTPUT (500mA Ground)**

Ground output when system is armed. This output is used for disabling the starter or to activate other devices such as scanner LED's, window modules, voice modules etc. For starter kill, cut starter wire and connect between 87A and 30 on relay. Connect orange wire to 85 and connect 86 to an Ignition source that has voltage in the ON and CRANKING position.

### **WHITE WIRE: +12V FLASHING PARKING LIGHT OUTPUT (Optional)**

Connect to switched parking light wire at back of light switch. If this is not possible, connect directly to one of the parking lights at the front of the vehicle. European vehicles require separate right and left circuits. Use a dual relay or 2 diodes to separate the output signal.

### **BROWN WIRE: (+) SIREN OUTPUT (3 Amp Max.)**

Connect to RED siren wire.

# WIRING

## **BLUE WIRE: (-) HOOD/TRUNK TRIGGER**

Input trigger for a grounding hood or trunk pin switch. Connect to existing hood and trunk pin switches that read ground when open. If no existing switches are available, install new pin switches if desired. Note: DO NOT mount new pin switches in water pathways.

## **GREEN WIRE: (-) DOOR TRIGGER**

Identify the wire that reads ground when any door is open and 12 volts when all doors are closed. Some vehicles may have isolated door triggers. In this case you may need to run additional wires from other doors or go directly to the wire that triggers the vehicle's dome light.

## **VIOLET WIRE: (+) DOOR TRIGGER**

Same as GREEN wire above except this wire is used for vehicles that show a positive voltage (12 volts) when the door is open such as Ford.

## **GRAY WIRE: (-) AUX REMOTE OUTPUT 1 (Optional, requires relay)**

Connect to terminal 85 of relay. Connect terminal 86 to constant. Connect terminal 87 to +12V or Ground depending on the type of circuit that needs to be activated. Connect terminal 30 to the device/circuit to be activated.

## **WHITE/RED WIRE: (-) AUX REMOTE OUTPUT 2 (Optional, requires relay)**

This wire connects the same way as Remote Output 1 see GRAY WIRE above.

## **BLACK/WHITE WIRE: (-) DOME LIGHT ILLUMINATION OUTPUT (Optional, requires relay)**

Connects to terminal 85 of a relay. Connect terminal 86 to +12V Constant. Connect terminal 87 to +12V or Ground depending on the type of dome light circuit in the vehicle. Connect terminal 30 to the dome light circuit.

## **BROWN/WHITE WIRE: (-) HORN HONK/CHIRP OUTPUT (Optional, requires relay)**

Connects to terminal 85 of a relay. Connect terminal 86 to +12V Constant. Connect terminal 87 to +12V or ground depending on the type of horn activation circuit in the vehicle. Connect terminal 30 to the horn activation circuit.

## **BLUE/WHITE WIRE: (-) PASSENGER(S) DOOR UNLOCK OUTPUT (Optional, requires relay)**

Connects to unlock circuit for passenger door(s) when using separate driver's door unlock option. See DOOR LOCK WIRING for configuration options.

## **2 PIN PLUG (BLUE): PROGRAM/OVERRIDE PUSH BUTTON**

## **2 PIN PLUG (RED): LED INDICATOR (RED FLASHING LIGHT)**

## **4 PIN SENSOR PLUG:**

**WHITE WIRE: NEG. WARN AWAY**

**BLUE WIRE: NEG. TRIGGER**

**BLACK WIRE: SENSOR GROUND**

**RED WIRE: SENSOR +12V POWER**

\*The Sensor supplied with the system does not require any additional wiring, simply mount the sensor in a suitable location, plug in, and adjust sensitivity.

# POWER DOOR LOCK WIRING

## 3 PIN DOOR LOCK PLUG (Optional):

**GREEN:** (-) Negative pulse for LOCK

**RED:** +12V Coil Power for external relays TERM 86.

**BLUE:** (-) Negative pulse for UNLOCK

**DETERMINING DOOR LOCK TYPE:** We recommend determining the type of locking system the vehicle has before connecting any wires. Incorrect connection will result in damage to the remote start and/or vehicle locking system. There are several types of door lock systems in vehicles today. Below is listed the many types of common locking systems:

**Negative trigger:** Most Japanese; Ford, New GM

**One wire dual voltage:** Newer /Chrys/Dodg/Plym; Ford Probe

**Reverse Polarity:** Chrys/Dodg/Plym; GM; Ford

**Semi-automatic:** Older Saab and Volvo

**Positive trigger:** Many GM; Some Chrysler

**Ground/open:** Some Nissan; Subaru

**Electric vacuum pump:** Pre-'95 Mercedes-Benz

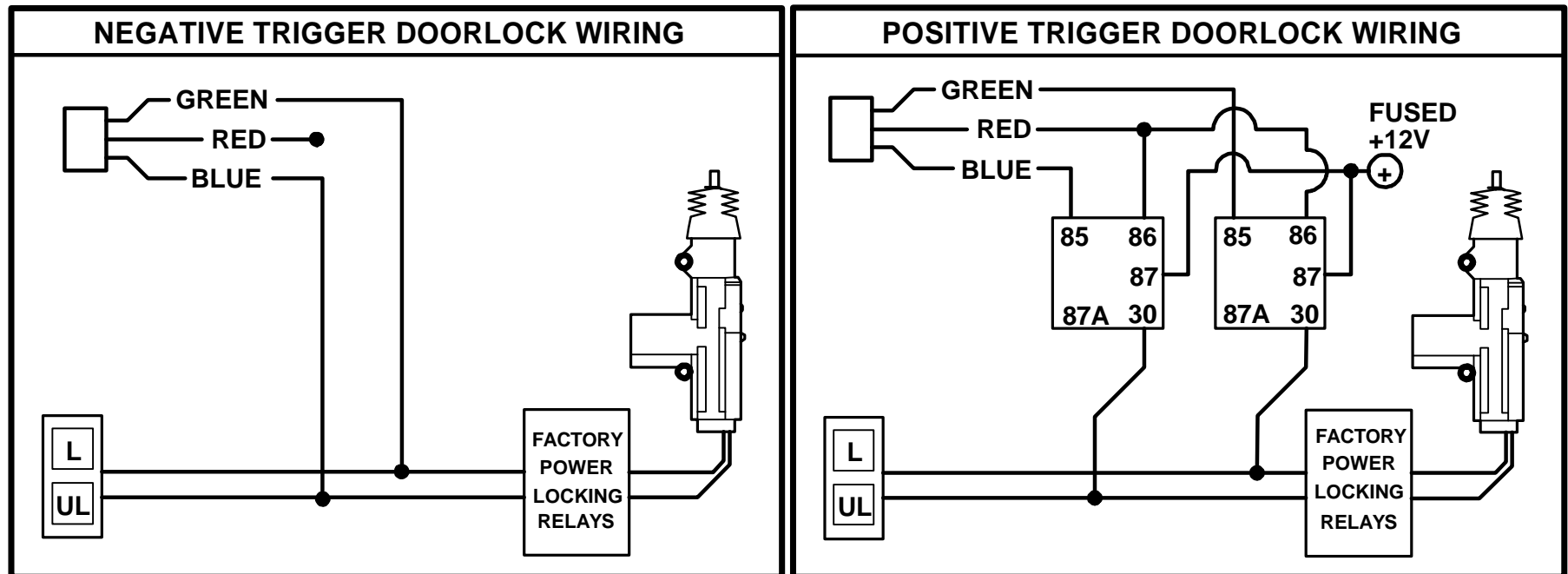

# POWER DOOR LOCK WIRING

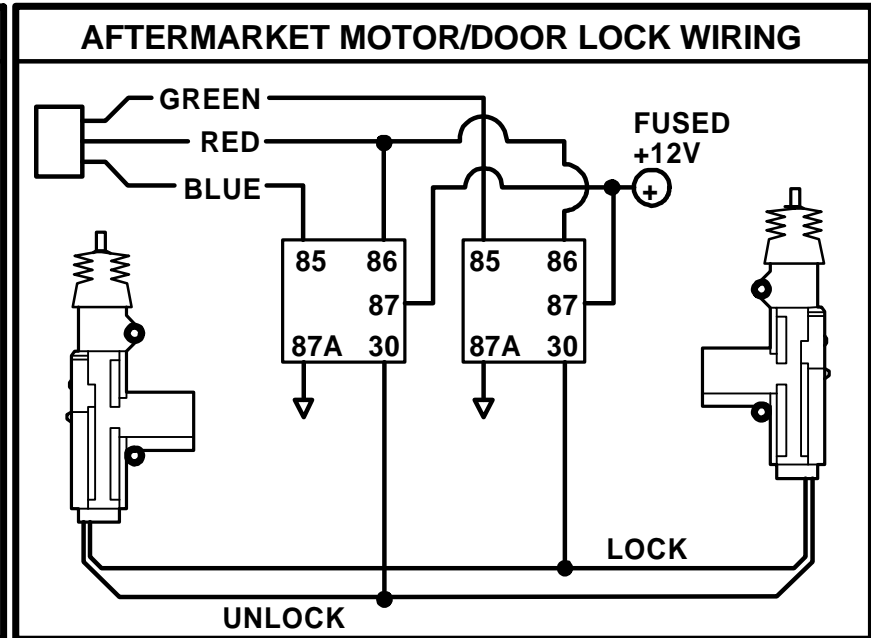
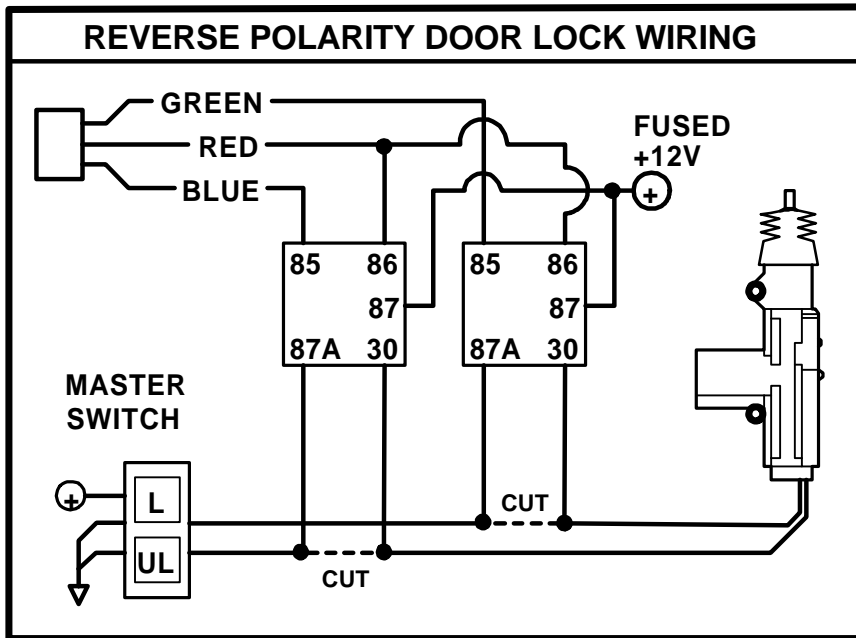

# SEPARATE DRIVER'S DOOR UNLOCK WIRING

## NEGATIVE TRIGGER DOOR LOCKS

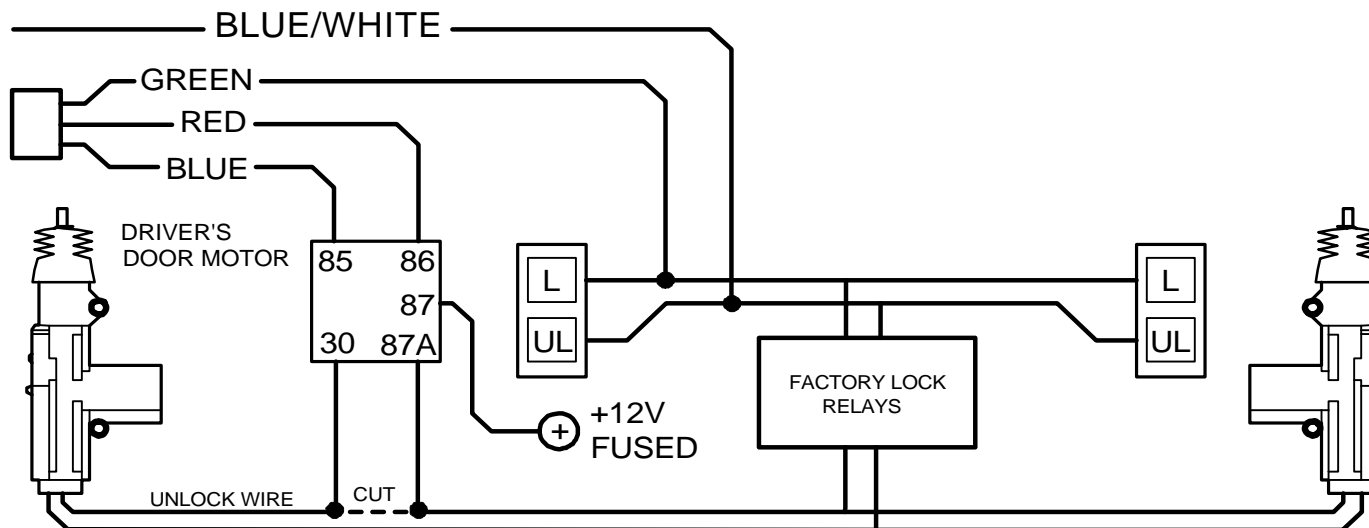



# TRANSMITTER PROGRAMMING

1. Turn Ignition ON and OFF 3 times quickly, leaving it ON the 3<sup>rd</sup> time. (ON/OFF, ON/OFF, ON) You should hear (3) chirps.
2. Push and release the Program/Override Button 5 times and the Status LED will come on solid.
3. Press #1 (LOCK) on new transmitter two times. LED goes out, siren chirps one time, and LED will flicker for confirmation.
4. Turn off Ignition.

**Note1:** Repeat steps 1 through 4 to teach the unit up to 3 transmitter codes Max.

**Note 2:** You can program button 4 (PANIC) from another vehicle's CS-2002DC alarm to Arm/Disarm *THIS* alarm system by pressing the other vehicles Button#4 two times in step 3. The Other transmitter will only toggle ARM/DISARM with button 4 and not perform any auxiliary features on *THIS* system.

## DIAGRAM:

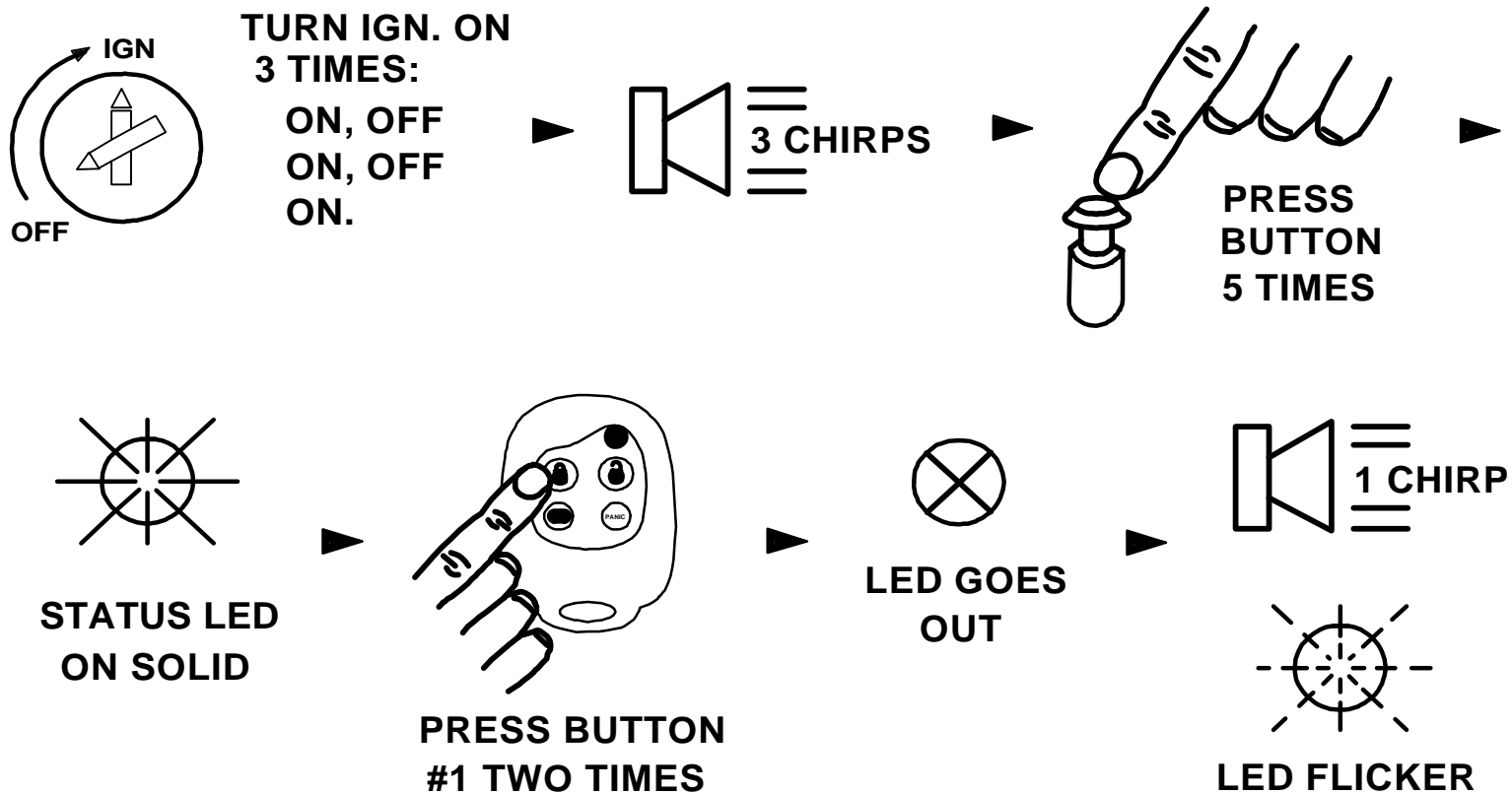

# OPTION PROGRAMMING

## CS-2002DC PROGRAMMABLE OPTIONS

1. Turn the Ignition ON and press the Override/Program button 5 times. You should hear 6 confirmation chirps.
2. Within the next few seconds, press the Override/Program button [again] the number of times that corresponds to the feature list below. The siren will chirp for each button press. **DO NOT LOSE COUNT!!**
3. When you get to the desired option number, press buttons #1, #2, or #3 (Lock, Unlock, Trunk) on the transmitter to change the option. Button 1 gives a single light flash, Button 2 gives two light flashes, and Button 3 gives three light flashes. See chart Below for Option descriptions and vales.
4. Change ONE option at a time repeating steps 1-3 as needed. When you are finished customizing options, check operation to see if the option(s) have changed.

### PROGRAMMING OPTIONS CHART

Option #	Option Description	BUTTON 1 LOCK (Default)	BUTTON 2 UNLOCK	BUTTON 3 TRUNK
1.	Passive Arming	ON	OFF	
2.	Quiet Chirp Arm/Disarm with Button #3	ON	OFF	
3.	Lights on with disarm	ON	OFF	
4.	Active Re-Arm	ON	OFF	
5.	Silent Arm/Disarm	OFF	ON	
6.	Disarm with trunk pop	OFF	ON	
7.	Ignition controlled Locks	ON	OFF	
8.	Door Lock Pulse Time	0.7 Sec.	3 Sec.	
9.	Carjack Enable/Disable	DISABLE	ENABLE	
10.	Lock with passive arm	ON	OFF	
11.	Double Unlock Pulse	OFF	ON	
12.	Type of Carjack Protection	ACTIVE	PASSIVE	FULL-TIME
13.	10/60 Sec. Door Open Warning	10 Sec.	60 Sec.	
14.	Horn Chirps	OFF	Arm/Disarm Only	Arm/Disarm/Pre-Warning

### 1. PASSIVE ARMING

This option controls the Passive (Automatic) Arming feature. If ON, arming will occur 30 Seconds after the ignition is turned off and the last door has been closed. The LED will begin flashing rapidly while counting down. If a door is reopened, the system will wait (LED solid) for the door or zone to close before arming. The unit will chirp once and flash the lights once. Doors will lock if passive locking is selected. Factory default setting is ON.

# OPTION PROGRAMMING

## 2. SOFT CHIRP ARM / DISARM WITH BUTTON #3 (SHORT PRESS)

With this feature, the system can be programmed to Arm and Disarm with a very soft siren chirp using a short press on button #3 on the remote. The Factory Default setting is ON.

## 3. PARKING LIGHTS ON WITH DISARM

Keeps parking lights on instead of 2 flashes when system is disarmed to assist in locating your vehicle in a crowded parking lot or structure. Light will stay on for 30 Sec. or until Ignition is turned on. Factory Default setting is ON.

## 4. ACTIVE RE-ARMING

Active Re-arming allows the system to re-arm itself 30 seconds after disarmed with the transmitter if a door has not been opened. This is handy if the vehicle is accidentally disarmed (via the Transmitter in your pocket) without you knowing it. The Factory default setting is ON.

## 5. SILENT ARMING /DISARMING (NO CHIRPS)

With this feature, the system can be programmed to Arm and Disarm without the siren chirp. Flashing parking lights will be the only Arm/Disarm confirmation. The Factory Default setting is OFF.

## 6. DISARM WITH AUX. OUTPUT 1

Controls whether the system will or will not DISARM when the trunk pop or AUX. feature is used. When the feature is turned on the unit will DISARM when opening trunk or other AUX feature. Factory Default setting is OFF

## 7. AUTOLOCK/UNLOCK

Controls whether the doors will automatically lock when the ignition is turned on and will unlock when the ignition is turned off. *Doors will not lock if they are open to prevent locking the keys in.* Factory default setting is ON

## 8. DOOR LOCK/UNLOCK PULSE TIME

Controls the amount of time (0.75 sec. or 3 sec.) for the lock/unlock pulse. The 3 sec. setting may be required for 1980'/90's European Vehicles that require a long pulse to do Vacuum door lock systems. Factory default is 0.75 sec.

## 9. CARJACK FEATURES

Enable or Disable Carjack protection features. Factory Default is OFF.

## 10. PASSIVE LOCKS

This option controls whether the doors will lock when Passive Arming occurs. Note: May increase the risk of locking keys in the vehicle. Factory default setting is ON.

## 11. DOUBLE UNLOCK PULSE

The unit will send 2 unlock pulses when the #2 Unlock button is pressed. This feature may be required for interfacing this alarm with an existing Factory Keyless Entry or Alarm system in a vehicle. These systems are found on some Nissan, VW, Toyota, and Lexus vehicles. Factory Default setting is OFF.

## OPTION PROGRAMMING

### 12. ACTIVE or PASSIVE CARJACK PROTECTION

This feature controls the alarm system's Carjack Mode for ACTIVE OR PASSIVE protection. Option number 9 Must be enabled to allow Carjack functions to operate. See Operation section for Carjack Features. Factory default is Active.

### 13. 10/60 Sec. DOOR/ZONE OPEN WARNING

This setting changes the delay time in which the alarm system begins to monitor the Door, Hood, or Trunk Zones. This is helpful on vehicles with a delayed dome light to prevent the alarm from giving warning chirps due to the vehicle's dome light staying on. Factory Default setting is 60 Sec.

### 14. HORN CHIRP W/ARM-DISARM

This option controls whether the alarm chirps the Factory car horn for ARM/DISARM if the optional car horn feature is installed.

## OPERATION

4 BUTTON REMOTE TRANSMITTER:

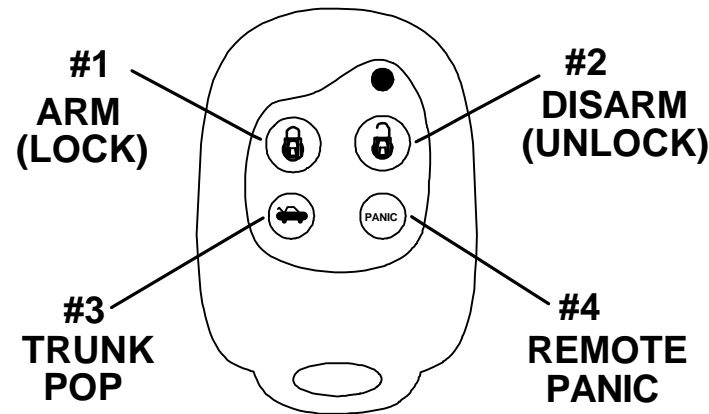

### ACTIVE ARMING

To arm the alarm and lock the doors, press the #1 (Lock Symbol) button on the transmitter. You will hear a single siren chirp and the lights will flash once. The system will arm, the doors will lock and the starter will be disabled if these optional features are installed. The red LED in the vehicle will start flashing after 15 seconds. After a short delay to allow vehicle and electronics to stabilize the system will be completely armed.

### ALARM TRIGGERING

If there is an intrusion into the vehicle or hard impact to the body will sound the alarm and flash the lights for 45 seconds. After 45 seconds the system will automatically shut off and re-arm to continue to protect the vehicle. If a door is left open then the unit will cycle a second time and continue to protect the other un-tampered zones.

# OPERATION

## DISARMING

To disarm the alarm and unlock the doors, press the #2 (Unlock Symbol) button on the transmitter. You will hear 2 siren chirps and the lights will flash twice. The dome light turns on and the dash LED stops flashing.

## TRUNK/HATCH POP (REMOTE AUX. OUTPUT 1, OPTIONAL)

To pop the trunk (if optional feature is installed), press Button #3 (Trunk Symbol) on the transmitter for at least 1 ½ seconds. *If the system is armed, pressing Button #3 may or may not trip the alarm system when opening the trunk depending on programming option (3) configuration. See page 9.*

## REMOTE PANIC PROTECTION

To sound the alarm upon command (panic), press and hold the Button #4 (Panic) for at least 2 seconds until the siren sounds. Press Button #2 (Unlock) to reset panic mode.

## ARMING WITHOUT SHOCK SENSOR/TRIGGER ZONES

A) To arm the alarm without Shock sensor protection, press button #1 as normal then press Button #4 (Panic) within 2 seconds. You will hear an extra siren chirp indicating shock sensor bypass.

B) To arm the system without ALL trigger zones press button #1 as normal then press Button #3 (Panic) within 2 seconds. Again you will hear an extra siren chirp indicating ALL zone bypass.

## PRE-WARNING SHOCK PROTECTION

If a low-level shock to the vehicle body is detected, the pre-warning sensor activates sounding 6 quick siren chirps and 1 light flash. Adjust the shock sensor as needed by turning the control knob clockwise to increase sensitivity and counter-clockwise to decrease sensitivity.

## EMERGENCY OVERRIDE/DISARM

If you have lost the transmitter or it stops working for any reason and the Alarm is armed, you will have to open the door with the key, which will activate the alarm. Turn the ignition on and press the override/program button about 2 seconds. The Alarm will disarm and enter the Valet mode that allows you to use the vehicle until you can repair/replace the remote transmitter at which time you can take the vehicle out of valet.

## VALET MODE

To disable the Alarm system for vehicle service or otherwise, turn the ignition on and press the override/program button until the dash LED turns on solid (about 5 seconds) and you hear (1) siren chirp. Repeat the process to exit VALET mode and the system will chirp (2) times and the LED will turn off. Lock/Unlock and AUX features will still operate in when in VALET mode.

# OPERATION

## **SOFT CHIRP ARM/DISARM**

This system can be armed and disarmed with very faint/soft chirps as needed. Press and quickly release Button #3 (Trunk pop) to Arm and Disarm system with soft chirps. Note: If Button #3 is pressed too long, then the Aux. 1 output will activate.

## **SILENT ARM/DISARM MODE**

The system can be silently armed and disarmed as normal with Lock/Unlock Buttons but no siren chirp. See alarm programming option (5) to enable or disable this feature.

## **PASSIVE ARMING / PASSIVE LOCK MODES**

If programmed, passive (Automatic) Arming will occur 30 Seconds after the ignition is turned off and the last door has been closed. The LED will begin flashing rapidly while counting down. If a door is reopened, the system will wait (LED solid) for the door or zone to close before arming. The unit will chirp once and flash the lights once. Doors will lock if passive locking is selected. May qualify for insurance discounts-check with your agent or proprietor.

## **PRIOR INTRUSION ALERT**

If the system was tripped in your absence, the dash LED will be flashing rapidly. When the system is disarmed you will hear 3 chirps (and 3 light flashes). Carefully inspect your vehicle to see if there is any damage or a theft has occurred.

## **DOME LIGHT ILLUMINATION (OPTIONAL)**

This feature turns on the vehicles dome light upon disarm for 30 seconds or until the key is inserted and turned on. This will provide illuminated entry to your vehicle at night or in dimly lit areas for safety and security.

## **DEFECTIVE ZONE ALERT/BYPASS**

If the system detects a faulty or open zone (Door left open) when the system is ACTIVELY ARMED, the siren will chirp 4 times along with 4 light flashes. The faulty zone will be automatically bypassed.

## **AUTOLOCK/UNLOCK**

The doors will automatically lock when the ignition is turned on and will unlock when the ignition is turned off. *Doors will not lock if they are open to prevent locking the keys in.*

## **ACTIVE RE-ARMING (FAIL-SAFE PROTECTION)**

Active Re-arming means that the system will re-arm itself 30 seconds after disarmed with the transmitter if a door has not yet been opened. This is handy if the vehicle is accidentally disarmed (via the transmitter in your pocket) without you knowing it. This feature can also be turned off in programming option (4).

# OPERATION

## **2<sup>nd</sup> AUX. OUTPUT (REMOTE AUX. OUTPUT 2)**

To activate the Second auxiliary output press Button #1 (Lock) and hold for more than (1) second. This output can be used to control other optional add-on accessories such as Remote Engine Start Modules, Window Roll up/down modules, etc.

## **2 VEHICLE CONTROL**

This unit can be programmed to Arm/Disarm a second vehicle with a CS-2002DC system installed. Follow the steps for transmitter programming on a second vehicle using Button #4 (Panic) from the existing remote. This will provide arm/disarm control of a second vehicle with the same transmitter using button#4.

# CARJACK PROTECTION

## **ACTIVE CARJACK**

This feature provides Active Carjack protection and must be enabled before use through Alarm programming options (9) & (12) See page 9. When the Ignition is on (vehicle is running), press button #4 (Panic). Parking lights will flash TWICE to confirm the Carjack countdown sequence. 90 Seconds later, the unit will begin a Carjack Cycle consisting of 15 seconds of pre-warning chirps turning into a full system activation with siren/flashing light pulses for up to 5 min. To reset Active Carjack, press Button #4.

## **PASSIVE CARJACK**

This feature provides Passive Carjack protection and must be enabled before use through Alarm programming options (9) & (12). See page 9. We recommend this mode should only be used in serious situations. When the Ignition is on (vehicle is running), if a door is opened the Carjack countdown sequence will be initiated. 90 Seconds later, the unit will begin a Carjack Cycle consisting of 15 seconds of pre-warning chirps turning into a full system activation with siren/flashing light pulses for up to 5 min. To reset Passive Carjack ignition has to be on DOOR MUST BE CLOSED, then press the override/program button (3) times.

## **FULL-TIME CARJACK**

This feature provides full-time Carjack protection and must be enabled before use through Alarm programming options (9) & (12). See page 9. EACH TIME the Ignition is turned on, a Carjack countdown sequence will be initiated. 90 Seconds later, the unit will begin a Carjack Cycle consisting of 15 seconds of pre-warning chirps turning into a full system activation with siren/flashing light pulses for up to 5 min. To reset Full-time Carjack, ignition has to be on, DOOR MUST BE then press the override/program button (3) times.

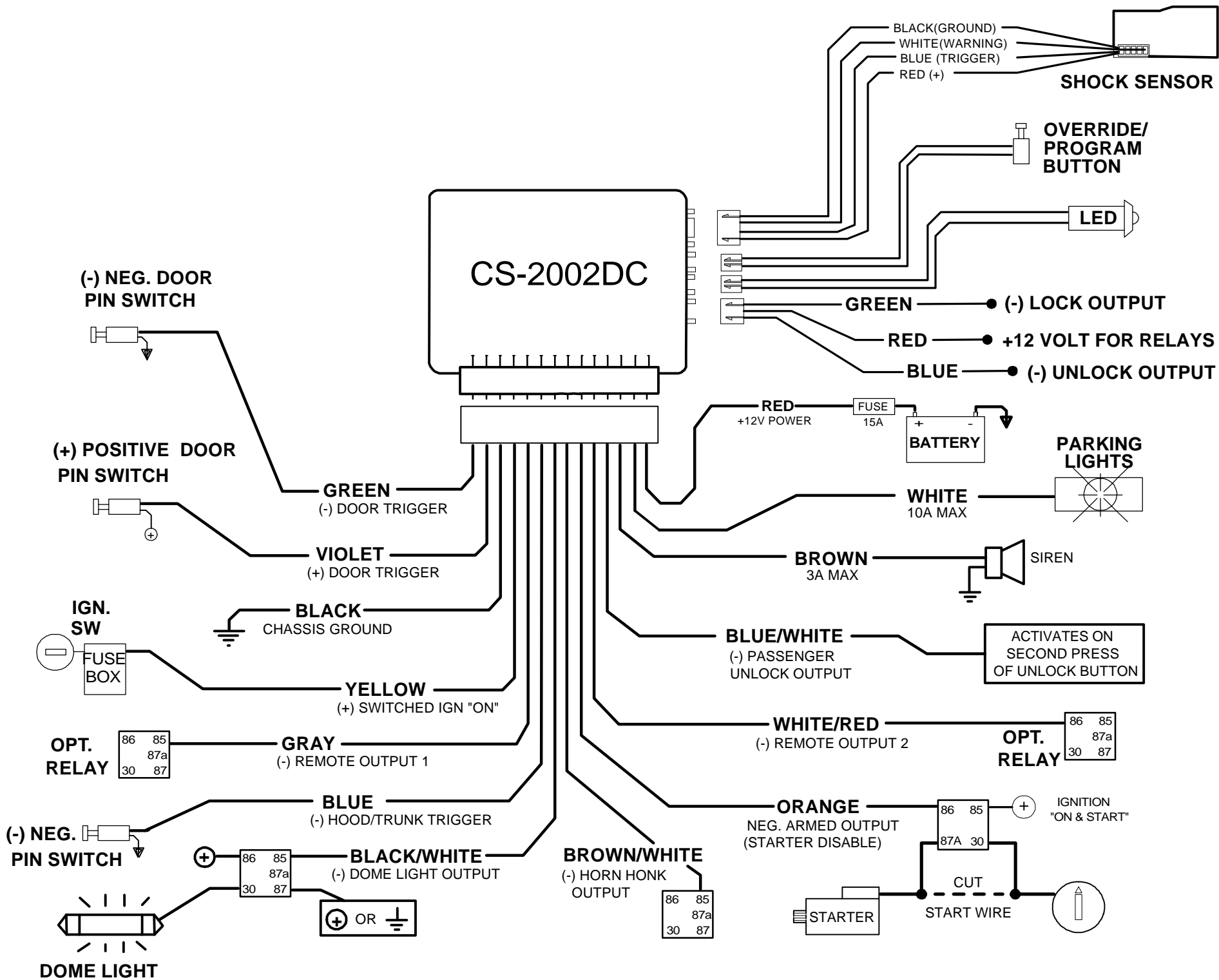

CS2002DC REVA 2.1.00

Crimestopper Security Products  
1770 S. Tapo Street  
Simi Valley, CA 93063