



CS-2000 Series III

REMOTE CONTROL ALARM SYSTEM INSTALLATION & OPERATING INSTRUCTIONS

INTRODUCTION

CONGRATULATIONS on your choice of an On-Guard Series Remote Alarm System by Crimestopper Security Products Inc. This booklet contains the information necessary for installing, using, and maintaining your alarm system. If any questions arise, contact your installation dealer or Crimestopper Security Products Inc. at the Tech Support number below.

****IMPORTANT INFORMATION: Primary and Optional Features:***

-PRIMARY: These are features that must be connected in order for the system to operate properly; i.e. the Siren, L.E.D., +12V Power, Ground, Doorpin, Override/Program/Valet Button etc.

-OPTIONAL: These are features to be connected if desired or agreed upon by the installing dealer. These features may also require additional parts and/or labor fees. Consult with your installer beforehand; i.e. Door Locks, Flashing Lights, Starter disable, Hood/Trunk trigger, and Auxiliary Remote Outputs etc.

TECH SUPPORT
Mon-Fri 8:00 AM-4:30 PM Pacific Time
(800) 998-6880

This device complies with FCC Rules part 15. Operation is subject to the following two conditions: 1) This device may not cause interference, and (2) this device must accept any interference that may be received, including interference that may cause undesired operation. The manufacturer is not responsible for any radio or TV interference caused by unauthorized modification to this equipment. Such modification could void the user's authority to operate the equipment.

TABLE OF CONTENTS

| | |
|--|-------|
| <i>Installation Cautions & Warnings</i> | 2 |
| <i>Control Module & Component Mounting</i> | 3 |
| <i>Wiring</i> | 4-5 |
| <i>Power Door Lock Wiring</i> | 6 |
| <i>Transmitter Programming</i> | 7 |
| <i>Option Programming</i> | 8-10 |
| <i>Operating Instructions</i> | 11-13 |
| <i>Car Jack Protection</i> | 14 |
| <i>System Wiring Diagram</i> | 15 |
| <i>2 Vehicle Operation</i> | 16 |

INSTALLATION CAUTIONS & WARNINGS

BEFORE BEGINNING, check all vehicle manufacturer cautions and warnings regarding electrical service (AIR BAGS, ABS BRAKES, ENGINE COMPUTERS, BATTERY etc.).

WE RECOMMEND the use of a VOLT/OHM METER to test and verify wiring circuits. Test lights or illuminated probes can cause damage to on-board computer or engine management systems.

DO NOT exceed maximum output ratings or damage may occur. Electrical current limits for this alarm are listed where applicable on the system diagram (Pg. 15). If you are unsure about the current load, of a specific circuit on your vehicle, measure the load first with an amp-meter before connecting.

WE RECOMMEND that the MAIN SYSTEM FUSE be REMOVED before jump starting, using a battery charger, or changing the battery. A voltage surge or high boost condition could damage alarm circuits.

DO NOT ROUTE ANY WIRING THAT MAY BECOME ENTANGLED with brake, and gas pedals, steering column, or any other moving parts in the vehicle.

CONTROL MODULE MOUNTING

DO NOT Mount the control unit in the engine compartment!

DO NOT Mount the control unit or wiring harness where they can become entangled with moving parts such as brake/gas/clutch pedals, or the steering column!

The alarm control module should be mounted in a concealed location. The Placement of the module will affect the distance from which the remote transmitter can control the unit. The antenna wire should be routed away from any metal if possible. Do not alter the length of the antenna wire or route it with other wires. Do not ground the antenna wire. Fasten the module to a bracket or wire harness using the cable ties provided.

Underdash Mounting: If you are locating the control unit underdash, mount it as high as possible, not easily located by an intruder.

Driver's Side Underdash mounting provides an easy location for wiring most of the system's connections, however this is a common location for an intruder to check for an alarm after breaking into the vehicle. The left side of the vehicle may contain more metal and or wiring that will create interference and decrease the operating range of the system.

Passenger Side underdash is a good location, however some extra wiring may be needed to extend wires across from the driver's side.

Under-seat / Center Console mounting is also a possibility, but NOT RECOMMENDED. The system's transmitter range will be reduced by the metal structures of the seat or center console and the unit may also be exposed to moisture from spilled drinks etc. Moisture or water damage is not covered under the warranty and will be subject to repair charges. Under seat or console mounting will create more difficulty if you need to access the unit for service or want to add-on features or connections later. Use this location as a last resort.

COMPONENT MOUNTING

SIREN: Mount the siren under the hood to an inner fender-well or other body surface with the open end facing downward.

LED: Mount the LED status indicator in a visible location on the dashboard or console.

Shock Sensor: Mount the included shock sensor with wire ties to an under dash wire harness or fasten with screws to firewall or side paneling. Use the adjustment screw to set the sensitivity of the sensor.

Valet/Override/Program Button: Mount the Valet/Override/Program push-button in a hidden but accessible location. It is REQUIRED for emergency disarm, programming, and valet mode.

WIRING

GREEN WIRE: (-) DOOR TRIGGER

Identify the wire that reads ground when any door is open and 12 volts when all doors are closed. Some vehicles may have isolated door triggers. In this case you may need to run additional wires from other doors or go directly to the wire that triggers the vehicle's interior dome light. One vehicle will not require the use of BOTH door trigger wires.

VIOLET WIRE: (+) DOOR TRIGGER

Same as the GREEN wire above except this wire is used for vehicles that show a positive voltage (12 volts) when the door is open and a ground when doors are closed as in many Ford, Lincoln, and Mercury vehicles.

BLACK WIRE: SYSTEM CHASSIS GROUND

The Black wire MUST be connected the CHASSIS METAL of the vehicle. Scrape away any paint or debris from the connection point and use a star washer to ensure a good connection. Keep the ground wire short.

YELLOW WIRE: IGNITION SWITCHED "ON" AND "START" +12 VOLTS

Connect to an IGNITION wire (or fuse in the fuse box) that shows +12 Volts when the key in both "On" and "Start" (WHEN CRANKING) positions.

GRAY WIRE: (-) AUX REMOTE OUTPUT 1 (Optional, may require a relay)

Connect to the Negative trunk release circuit or to the activation circuit of an auxiliary module or device. If the circuit requires +12V, then a relay is required. RELAY WIRING: Connect the Gray wire to terminal 85, connect relay terminals 86 and 87 to +12V constant power. Connect terminal 30 of the relay to the +12V positive device/circuit to be activated.

BLUE WIRE: (-) HOOD/TRUNK TRIGGER (Optional)

Input trigger for a grounding hood or trunk pin switch. Connect to existing hood and trunk pin switches that read ground when open. If no existing switches are available, install new pin switches if desired. Note: DO NOT mount new pin switches in water pathways.

BLACK/WHITE WIRE: (-) DOME LIGHT ILLUMINATION OUTPUT (Optional, requires a relay)

Connect Black/White wire to terminal #85 of a relay. (Relay not included) Connect terminal #86 of relay to +12 Volt Constant power. For POSITIVE dome light circuits, connect Terminal #87 to fused +12V Constant. For NEGATIVE Dome light circuits, connect terminal #87 to chassis ground. Connect terminal of the #30 of the relay to the dome light activation circuit in the vehicle.

WIRING

BROWN/WHITE WIRE: (-) HORN PULSE / CHIRP OUTPUT (Optional, may require a relay)

Connect to the Negative Horn Trigger wire usually located near the steering column. If the vehicle horn circuit requires +12V, then a relay is required. RELAY WIRING: Connect the Brown/White wire to terminal 85, connect relay terminals 86 and 87 to +12V constant power. Connect terminal 30 of the relay to the +12V positive device/circuit to be activated.

ORANGE WIRE: (-) NEGATIVE ARMED OUTPUT / STARTER DISABLE (500mA Ground, Optional)

This wire becomes a (-) Ground output when system is armed. This output is used for disabling the starter or to activate optional devices such as extra sensors, LED's, window roll-up modules, voice modules etc. For starter kill, cut starter wire and connect between 87A and 30 on relay. Connect orange wire to 85 and connect 86 to an Ignition source that has voltage in the ON and CRANKING position. (See wiring diagram for relay configuration-Pg. 15)

WHITE/RED WIRE: (-) AUX REMOTE OUTPUT 2 (Optional, may require a relay)

This wire connects the same way as Remote Output 1 see GRAY WIRE last page.

BLUE/WHITE WIRE: NOT USED / NO CONNECTION

BROWN WIRE: (+) SIREN OUTPUT (3 Amp Max.)

Connect to RED siren wire from the Siren in the engine compartment.

WHITE WIRE: +12V FLASHING PARKING LIGHT OUTPUT

Connect to the switched parking light wire at back of light switch. If this is not possible, connect directly to one of the parking lights at the front of the vehicle. European vehicles require separate right and left circuits. Use a dual relay or 2 diodes to separate the output signal.

RED WIRE: +12V POWER INPUT (15 amp fuse)

Connect to +12 Volt source with supplied fuse & holder. Recommended location for this connection is at the vehicle battery positive terminal.

2 PIN PLUG (BLUE): PROGRAM/OVERRIDE PUSH-BUTTON

2 PIN PLUG (RED): LED INDICATOR (RED FLASHING LIGHT)

4 PIN SENSOR PLUG: **WHITE** Wire: Negative Trigger,
BLUE Wire: Negative Warn Away, **BLACK** Wire: Sensor
Ground, **RED** Wire Sensor +12V Power

SHOCK SENSOR: The sensor supplied with this system does not require any additional wiring. Simply mount the sensor in a suitable location, plug it in, and adjust sensitivity. Note the wiring of this shock sensor is different than previous CS-2000 models.

POWER DOOR LOCK WIRING

3 PIN DOOR LOCK PLUG (Optional):

GREEN: (-) Negative LOCK Pulse, **RED:** +12V Coil Power for relays, **BLUE:** (-) Negative UNLOCK Pulse

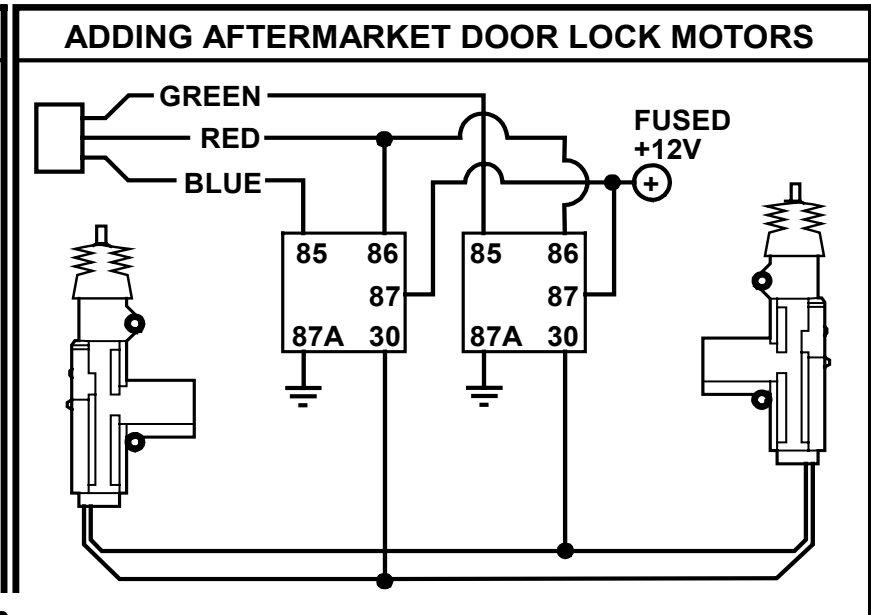
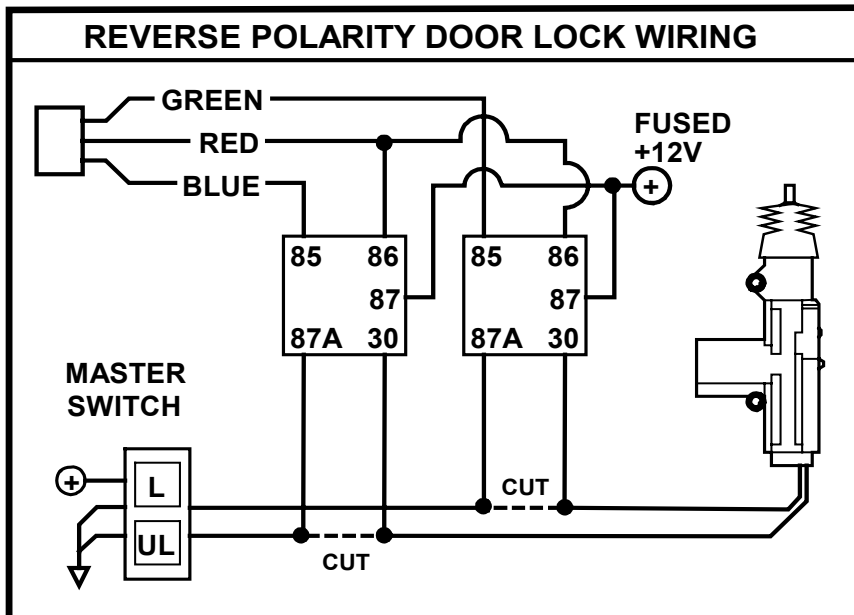
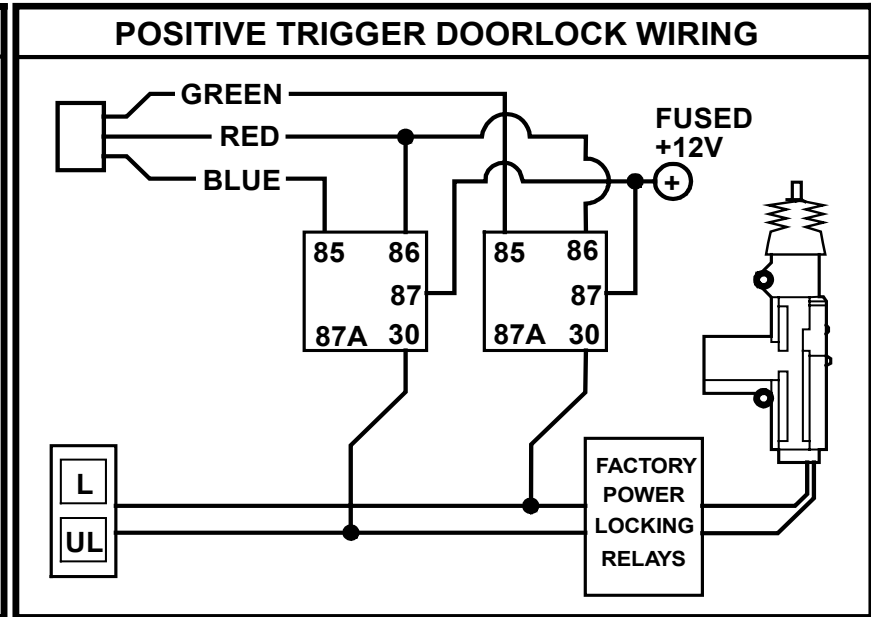
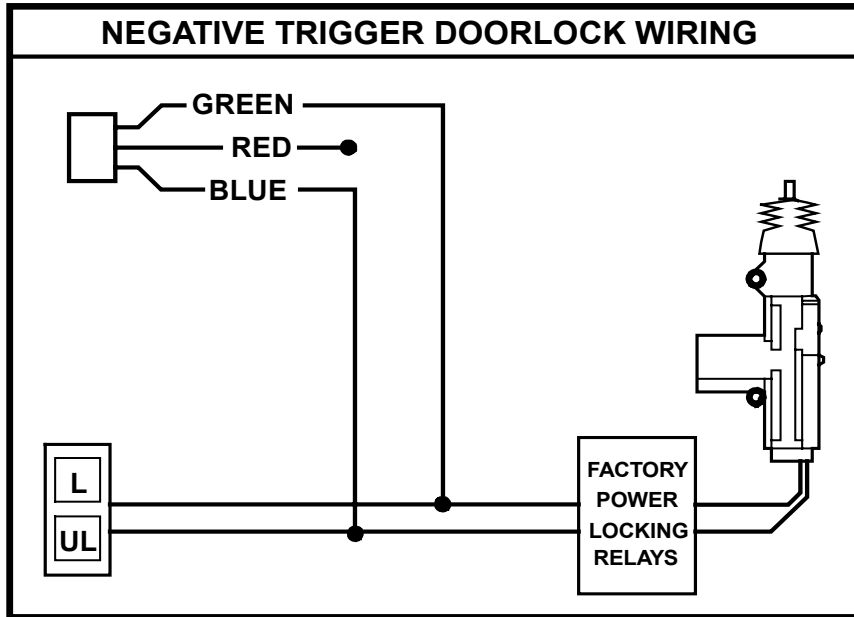

REMOTE TRANSMITTER PROGRAMMING

1. Turn Ignition ON.
2. Press the Program/Override Button 4 times. After a few second delay, the lights should flash 4 times.
3. Press button 1 on the remote control you wish to learn. You should get 2 light flashes indicating the unit is waiting for a 2nd code, then press button #1 of a second transmitter or transceiver, the unit will flash 3 times indicating its waiting for the 3rd code and lights will flash 4 times for 4th code. If all 4 codes are learned, the unit will automatically exit code-learning mode, otherwise turn key off to exit programming mode.

Note 1: All transmitter codes must be learned at the time of programming. Any transmitters not present will be dropped from system memory. This system will learn a total of 4 transmitters max.

DIAGRAM:

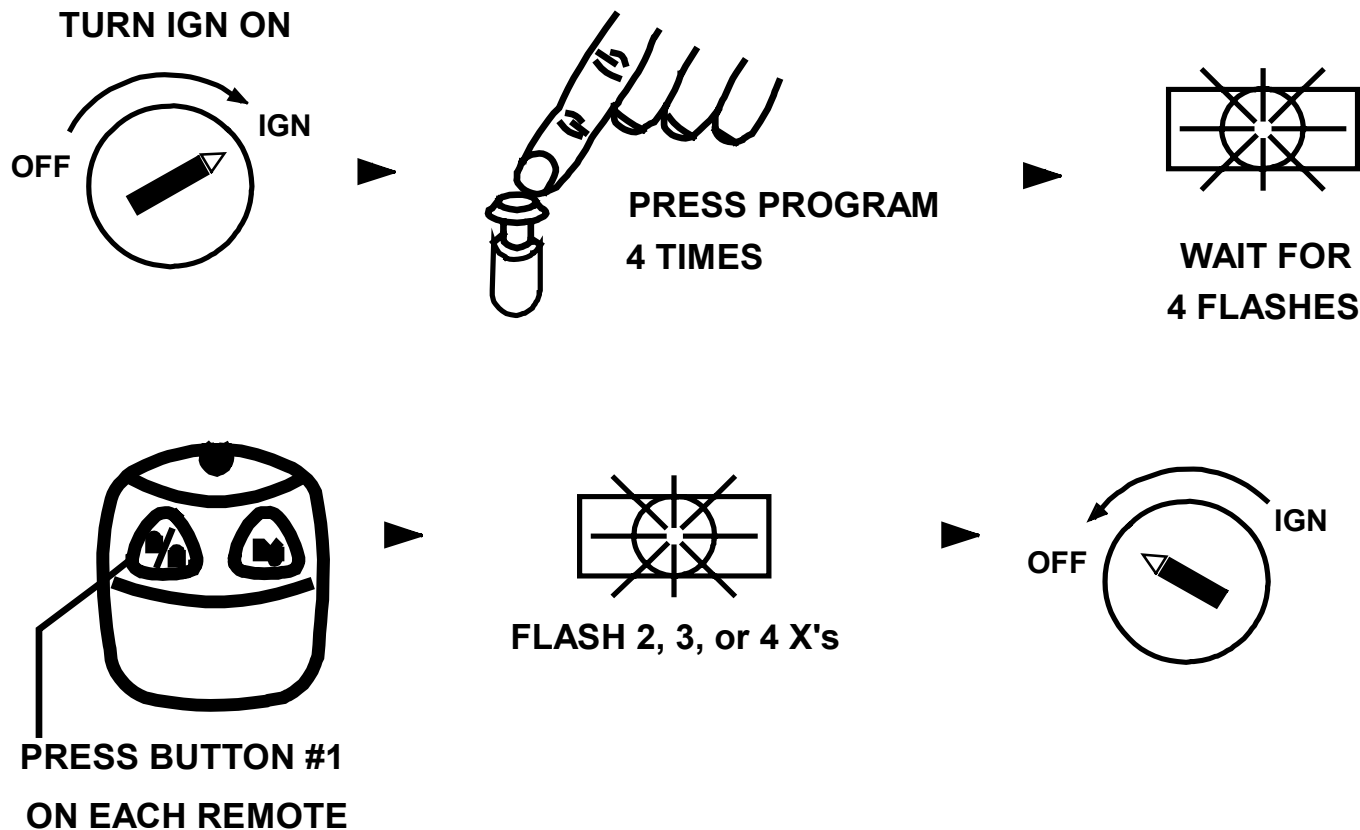

OPTION PROGRAMMING

1. Turn the Ignition ON and press the Override/Program button 5 times. After a slight delay, the system will flash the lights 5 times.
2. Within the next few seconds, press the Override/Program button [again] the number of times that corresponds to the feature list below. The siren will chirp for each button press. **DO NOT LOSE COUNT!!**
3. When you get to the desired option number, press the appropriate button on the transmitter according to the chart below. Turn Ignition off. See Below for Option numbers, descriptions, and values. (Button 1 gives a single light flash/chirp, Button 2 gives two light flashes/chirps, and Buttons (1+2) together gives three light flashes/chirps.)
4. Change ONE option at a time repeating steps 1-3 as needed. When you are finished customizing options, check operation to see if the option(s) have changed.

PROGRAMMING OPTIONS CHART

* = Default Settings

| Option # | Option Description | BUTTON 1 LOCK | BUTTON 2 UNLOCK | BUTTONS (1+2) TOGETHER |
|----------|---|----------------------|-------------------------------------|---|
| 1. | Factory Horn Chirps / Pulses | Pulse with trip only | Arm/Disarm Chirps & Pulse with trip | Arm/Disarm/Warn Chirp & Pulse with trip * |
| 2. | Passive Arming / Passive Chirp Countdown | ON | OFF* | Passive Arm with Chirp Countdown |
| 3. | Passive Lock | ON | OFF* | |
| 4. | Ignition controlled Locks | ON* | OFF | Ignition Lock Only |
| 5. | 10/60 Sec. Door Open Warning | 10 Sec. | 60 Sec.* | |
| 6. | Active Re-Arm | Enabled* | Disable | |
| 7. | Double Unlock Pulse | Disabled* | Enable | |
| 8. | Silent Arm/Disarm (Chirp Defeat w/Button 1) | Disabled* | Enable | |
| 9. | Parking Lights on with disarm | Enabled* | Disable | |
| 10. | Disarm with trunk pop | Disable | Enabled* | |
| 11. | Silent Arm/Disarm with Remote (Button #2) | Enabled* | Disable | |
| 12. | Door Lock Pulse Time | 0.75 Sec.* | 3 Sec. | |
| 13. | Type of Carjack Protection | Active* | Active & Passive | Full-Time |
| 14. | Carjack Features Enable/Disable | Disabled* | Enable | |
| 15. | L/UL or Arm/Disarm w/IGN ON | Lock/Unlock* | Arm/Disarm | |

NOTE: Options can be instantly restored to Factory Default Values: To restore default values: Perform step #1 above, then press buttons (1+2) together. The siren will chirp 4 times and lights will flash 4 times. Turn OFF Ignition. All programming options should be restored to “*” values (See chart above). 8

OPTION PROGRAMMING

1. HORN CHIRPS / PULSES

This option controls the system's Horn-honk output. There are 3 selections: Button 1 (Lock) = Horn Pulse only when alarm is tripped. Button 2 (Unlock) = Horn Chirps for Arm / Disarm and Pulse when tripped. Buttons (1+2) = Horn Chirps for Arm, Disarm, and Pre-warning protection. The horn output pulses when triggered.

2. PASSIVE ARMING / CHIRP COUNTDOWN

This option controls the Passive (Automatic) Arming feature. If ON, arming will occur 30 Seconds after the ignition is turned off and the last door has been closed. The LED will begin flashing rapidly while counting down. If a door is reopened, the system will wait (LED solid) for the door or zone to close before arming. The unit will chirp once and flash the lights once. Doors will lock if passive locking is selected. Factory default setting is OFF. If Passive Chirp countdown is selected, the System will produce a siren chirp every 2 seconds during countdown until the system arms.

3. PASSIVE LOCKS

This option controls whether the doors will lock when Passive Arming occurs. **Note: This feature may increase the risk of locking keys in the vehicle.**

4. IGNITION-CONTROLLED LOCKS

This option controls whether the locks are controlled by Ignition. There are 3 selections: Button 1 (Lock) = Lock/Unlock with vehicle Ignition. Button 2 (Unlock) = No ignition locks. Buttons (1+2) = Ignition lock only. *Doors will not lock if they are open to prevent locking the keys in.*

5. 10/60 Sec. DOOR OPEN WARNING

This setting changes the delay time in which the alarm system begins to monitor the Door circuit. This option can prevent the alarm from giving warning chirps on vehicles with a delayed dome light.

6. ACTIVE RE-ARMING

Active Re-arming allows the system to re-arm itself 30 seconds after disarmed with the transmitter if a door has not been opened. This is handy if the vehicle is accidentally disarmed (via the Transmitter in your pocket) without you knowing it. If Chirp Countdown selected the system will chirp every 2 seconds during the 30 second count down to active re-arming.

7. DOUBLE UNLOCK PULSE

The unit will send 2 unlock pulses when the #2 Unlock button is pressed. This feature may be required for interfacing this alarm with an existing Factory Keyless Entry or Alarm system in a vehicle. These systems are found on some Nissan, VW, Toyota, and Lexus vehicles. 9

OPTION PROGRAMMING

8. SILENT ARMING /DISARMING (CHIRP DEFEAT)

With this feature, the system can be programmed to Arm and Disarm without the siren chirp using the regular Lock/Unlock Button. Flashing parking lights will be the only Arm/Disarm confirmation.

9. PARKING LIGHTS ON WITH DISARM

Keeps parking lights on instead of 2 flashes when system is disarmed to assist in locating your vehicle in a crowded parking lot or structure. Light will stay on for 30 Sec. or until Ignition is turned on.

10. DISARM WITH AUX. OUTPUT 1 (TRUNK POP)

Controls whether the system will or will not DISARM when the trunk pop or AUX. feature is used. When the feature is turned on the unit will DISARM when opening trunk or using an auxiliary device controlled by the Gray output wire.

11. SILENT ARM / DISARM WITH REMOTE BUTTON #2 (QUICK PRESS)

With this feature, the system can be programmed to Arm and Disarm without a siren chirp using a short press and release of Button #2 on the remote transmitter.

12. DOOR LOCK/UNLOCK PULSE TIME

Controls the amount of time (0.75 sec. or 3 sec.) for the lock/unlock pulse. The 3 sec. setting may be required for 1980'/90's European Vehicles that require a long pulse to do Vacuum door lock systems.

13. ACTIVE, PASSIVE, or FULL-TIME CARJACK PROTECTION

This feature controls the type of Carjack protection the alarm will provide. There are 3 selections: Button 1 (Lock) = Active protection. Button 2 (Unlock) = Passive protection. Buttons (1+2) = Full-Time protection. Option number 14 must be enabled to allow Carjack functions to operate. See Operation Instructions: Carjack.

14. CARJACK FEATURES

This option controls the unit's Car Jack features. Enable or Disable Carjack (Turn ON or OFF) with this option.

OPERATING INSTRUCTIONS

ACTIVE ARMING

To arm the alarm and lock the doors, press the #1 Button (Lock/Unlock Symbol) on the transmitter. You will hear a single siren chirp and the lights will flash once. The system will arm, the doors will lock and the starter will be disabled if these optional features are installed. After a short 15 second delay to allow vehicle and electronics to settle, the system will be completely armed. The red LED in the vehicle will begin flashing.

ALARM TRIGGERING

If there is an intrusion into the vehicle or hard impact to the body will sound the alarm and flash the lights for 45 seconds. After 45 seconds the siren and lights will stop, but the alarm is still armed to continue to protect the vehicle. If an intruder left the door open, the unit will cycle a second time before stopping and then continue to protect the other un-tampered zones of the vehicle.

DISARMING

To disarm the alarm and unlock the doors, press the #1 Button (Lock/Unlock Symbol) on the transmitter. You will hear 2 siren chirps and the lights will flash twice. LED stops flashing. Doors will unlock and dome light will turn on if these optional features are installed.

ALARM TRIGGER RESET

If the armed alarm system is triggered while you are within the range of the remote, pressing the #1 Button will only shut off the siren and lights while leaving the alarm still in an armed status. To disarm the alarm when it is in a triggered status, you must press the #1 Button twice.

REMOTE PANIC PROTECTION

To sound the alarm upon command (panic), press and hold Button #1 for at least 4 seconds until the siren sounds. Press Button #1 again to reset panic mode.

TRUNK/HATCH POP (REMOTE AUX. OUTPUT 1, OPTIONAL)

To pop the trunk (if optional feature is installed), press Button #2 (Trunk Symbol) on the transmitter for at least 2 seconds. *If the system is armed, pressing Button 2 may or may not trip the alarm system when opening the trunk depending on programming option (10). See page 8.*

4 BUTTON REMOTE TRANSMITTER:

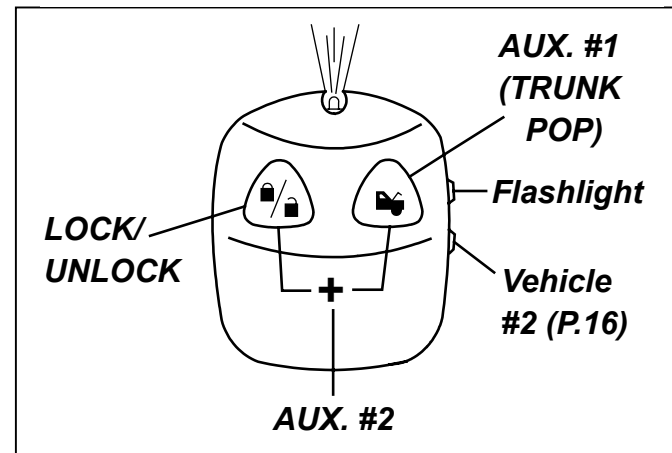

OPERATING INSTRUCTIONS

PRE-WARNING SHOCK PROTECTION & SENSOR ADJUSTMENT

If a low-level shock to the vehicle is detected, pre-warning protection will activate sounding 6 quick siren chirps and 1 light flash. If a hard impact is detected the shock sensor should trip the alarm system. Once it is mounted, adjust the sensor as needed by turning the adjustment screw clockwise to increase or counter-clockwise to decrease the sensitivity. The sensor is also equipped with 2 small indicator lights to ease the adjustment process. Green light = Pre-warning disturbance (6 siren chirps). Red light = A full alarm trigger.

SILENT ARM/DISARM THROUGH REMOTE (BUTTON #2)

This system can be armed and disarmed without siren chirps on an “as needed” basis. Press and quickly release Button #2 (TRUNK) to Arm and Disarm system without chirps. NOTE: If Button #2 is pressed too long, then trunk pop may activate if optional Trunk-pop feature is connected to the system.

PROGRAMMABLE SILENT ARM/DISARM MODE

The system can be silently armed and disarmed as normal with the Lock/Unlock Button, without siren chirps. See alarm programming option #8 on page 8 to enable or disable this feature.

EMERGENCY OVERRIDE & DISARM

If you have lost the transmitter or it stops working for any reason and the Alarm is armed, you will have to perform an emergency override & disarm to shut the alarm off. Open the door with the key, (alarm will sound). Turn the ignition on and press the override/program button 4-5 seconds (until siren stops). The Alarm will disarm and enter the Valet mode, which allows you to use the vehicle until you can repair/replace the remote transmitter or have the alarm system checked by an installer.

VALET MODE

To disable the Alarm system for vehicle service or otherwise, turn the ignition on and press the override/program button 4-5 seconds until the dash LED turns on solid and you hear (1) siren chirp. Repeat the process to exit VALET mode and the system will chirp (2) times and the LED will turn off. Lock/Unlock and AUX features will still operate in when in VALET mode.

PRIOR INTRUSION ALERT

If the system was tripped in your absence, the dash LED will be flashing rapidly. When the system is disarmed you will hear 1 chirp, then 2 additional chirps/flashes. Carefully inspect your vehicle.

OPEN ZONE ALERT & BYPASS

If the system detects a faulty or open zone (Door left open) when the system is ACTIVELY ARMED, the siren will chirp 5 times along with 5 light flashes. The faulty zone will be automatically bypassed.

OPERATING INSTRUCTIONS

IGNITION-CONTROLLED DOORLOCKS

If this feature is enabled, the doors will automatically lock when the ignition is turned on and will unlock when the ignition is turned off. This feature can be programmed on, off, or to lock the doors only. *Doors will not lock if they are open to prevent locking the keys in.*

PASSIVE ARMING / PASSIVE LOCK MODES / PASSIVE CHIRP COUNTDOWN

If programmed, passive (Automatic) Arming will occur 30 Seconds after the ignition is turned off and the last door has been closed. The LED will begin flashing rapidly while counting down. If a door is reopened, the system will wait (LED solid) for the door or zone to close before arming. The unit will chirp once and flash the lights once. Doors will lock if the "Passive Locking" feature is enabled. Passive Arm/Lock may qualify for insurance discounts-check with your agent or proprietor. When the Unit is programmed for Passive Chirp Countdown, the siren will chirp during passive countdown, as an audible warning that arming will occur. The siren will chirp every 2 seconds as soon as the last door is closed until the system arms 30 seconds later.

DOME LIGHT ILLUMINATION (OPTIONAL)

This feature turns on the vehicles dome light upon disarm for 30 seconds or until the key is inserted and turned on. This will provide illuminated entry to your vehicle at night or in dimly lit areas for safety and security.

ACTIVE RE-ARMING (FAIL-SAFE PROTECTION)

The Active Re-arming feature allows the system will re-arm itself 30 seconds after being disarmed with the transmitter if a door has not yet been opened. This is handy if the vehicle is accidentally disarmed (via the transmitter in your pocket) without you knowing it. This feature can also be turned off in programming option #6. If programmed for Passive Chirp Countdown, the unit will emit a chirp every 2 seconds until the system Active Re-arms.

2nd AUX. OUTPUT (REMOTE AUX. OUTPUT 2)

To activate the Second auxiliary output press Buttons (1+2) together for (2) seconds. This output can be used to control optional add-on accessories such as a window control module. If installing an add-on on remote start unit, you must use the GRAY AUX#1 channel, not Aux #2.

ARM/DISARM WITH IGNITION ON (PROGRAM OPTION #15)

This feature allows the system to be armed or disarmed while the ignition is in the ON position or vehicle is running. The feature is disabled by default and should not be used under normal operating conditions. In some rare instances where an add-on remote start module is used, this option can be enabled to allow the CS-2000 alarm to be armed or disarmed when the vehicle is remote started (Ignition ON).

CARJACK PROTECTION

ACTIVE CARJACK

This feature provides Active Carjack protection and must be enabled before use through Alarm programming option (14) See page 8. When the Ignition is on (running), press button #2 (Trunk Symbol). Parking lights will flash TWICE to confirm the Carjack countdown sequence. 90 Seconds later, the unit will begin a Carjack Cycle consisting of 25 seconds of pre-warning chirps turning into a full system activation with siren/flashing light pulses for up to 5 min. To reset Active Carjack, IGNITION MUST BE ON, then press Button #2 again.

PASSIVE CARJACK

This feature provides Passive Carjack protection and must be enabled before use through Alarm programming options (13) & (14). See page 8. We recommend this mode should only be used in serious situations. When the Ignition is on (vehicle is running), and a door is opened, the Carjack countdown sequence will be initiated. 90 Seconds later, the unit will begin a Carjack Cycle consisting of 25 seconds of pre-warning chirps turning into a full system activation with siren/flashing light pulses for up to 5 min. To reset Passive Carjack, IGNITION MUST BE ON AND DOORS MUST BE CLOSED, then press the override/program button (3) times.

FULL-TIME CARJACK

Use in case of extreme Carjack threat only. This feature provides full-time Carjack protection and must be enabled before use through Alarm programming options (13) & (14). See page 8. EVERY TIME the Ignition is turned ON or a door is opened, then closed with the Ignition ON, a Carjack countdown sequence will be initiated. 90 Seconds later, the unit will begin a Carjack Cycle consisting of 25 seconds of pre-warning chirps turning into a full system activation with siren/flashing light pulses for up to 5 min. You must reset the unit every time the IGNITION is turned on or a door is opened and closed when the ignition is on. To reset IGNITION MUST BE ON AND DOORS MUST BE CLOSED, then press override/program button (3) times.

NOTE: When FULL TIME CARJACK is in effect, it must be reset every time the key is turned on, Door is opened, before entering VALET mode, and before Programming options or transmitters. It is always in effect each time the Ignition is turned on and/or a door is opened with Ignition on.

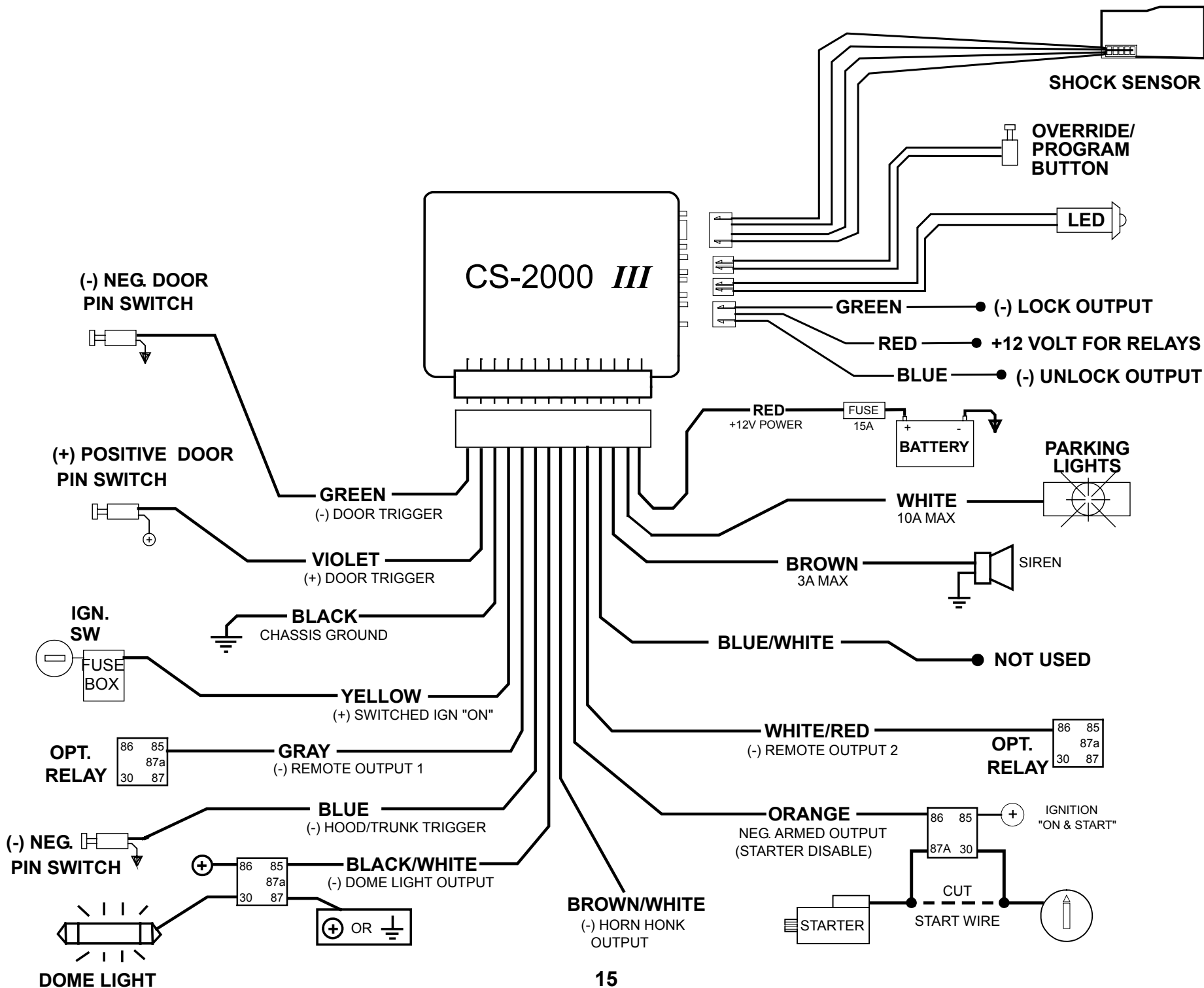

2-VEHICLE OPERATION

SETUP:

See diagram at right on how to use your remote for vehicle #2 operation. To set up your remote, follow the "Transmitter Programming" steps (Page 7) *ON THE SECOND VEHICLE* and learn YOUR remote, along with Car #2's existing remotes. In step #3 press the side button on YOUR remote first, then press the Lock/Unlock button. Your vehicle should now be programmed for the second vehicle.

2-VEHICLE OPERATION:

Press the side button on your remote first, and within 3 seconds, press a function button on YOUR remote. You can keep pressing function buttons to control car #2 as long as it is within the 3-second window. After 3 seconds have elapsed, the your remote will revert back to Car #1 control.

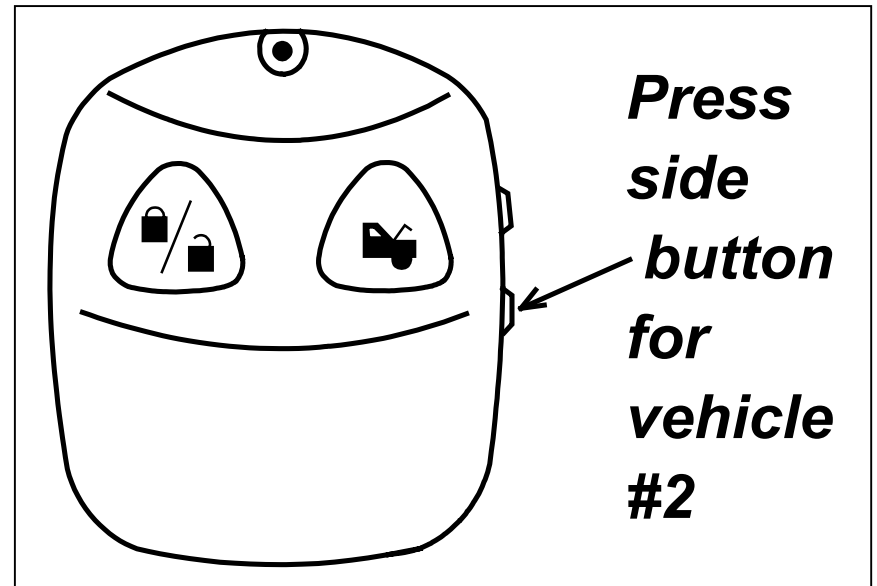

CRIMESTOPPER

www.crimestopper.com
email@crimestopper.com
Phone (800) 998-6880
FAX (805) 581-9500

TechWeb

ONLINE TECHNICAL SUPPORT
www.crimestopper.com/techweb03.html